

UG8 models with PST sampling tube

Installation instruction

Uniguard 8

Mounting and positioning

The Uniguard should be installed according to the drawing below. The Uniguard can be installed on any side of the duct.

We recommend that the Uniguard is mounted at an equal distance from sources of interference, and similar to the siting of flow monitors. A distance of 2 times the duct hydraulic diameter should be left before a source of interference, and 5 times the hydraulic diameter after. This positioning ensures uniform mixing if turbulent airflow occurs in the ventilation ducts.

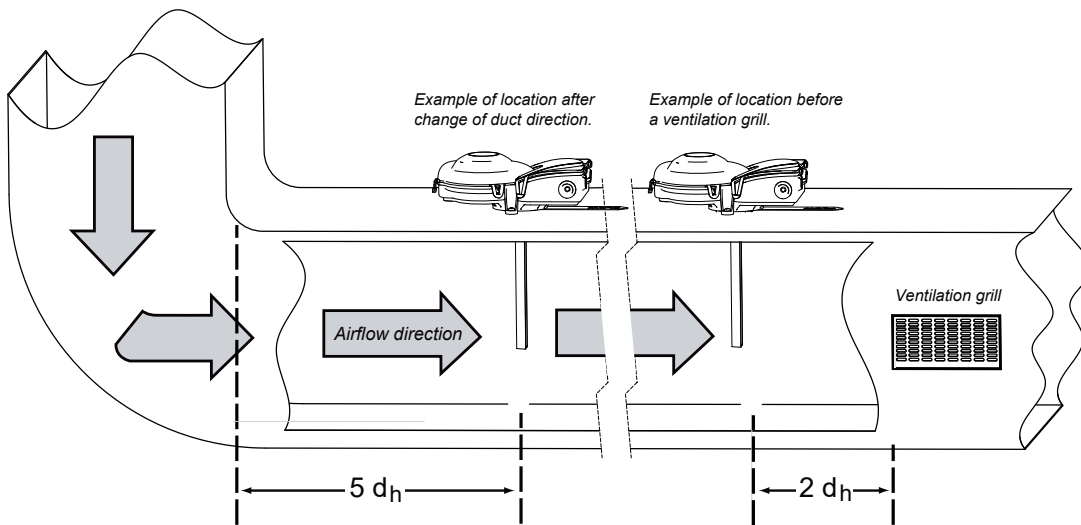

Where large temperature variations occur, e.g. on outdoor locations or in areas subject to external temperatures (roof, attics), the Uniguard must be insulated, see para 7.

Hydraulic diameter (d_h)

CIRCULAR DUCT

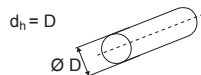

RECTANGULAR DUCT

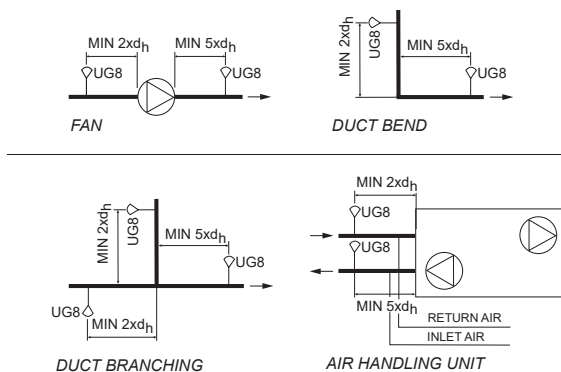
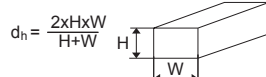

Example of installation at sources of interference:

- fan
- damper
- silencer
- battery
- air handling unit
- duct bend
- duct branching
- duct narrowing or expansion

1

Installation for different mounting conditions

Ducts $\varnothing < 200$ mm (2/3 ft)

1. For ducts smaller than 200 mm (2/3 ft), use mounting bracket UG-MB-8.
2. Do not cut the sampling tube PST195.
3. The sampling tube for UG8 should never penetrate the duct.

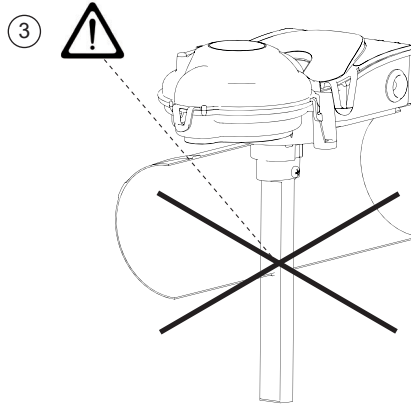
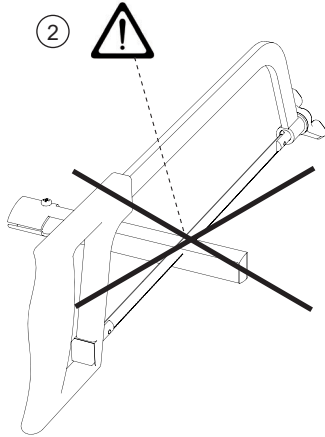
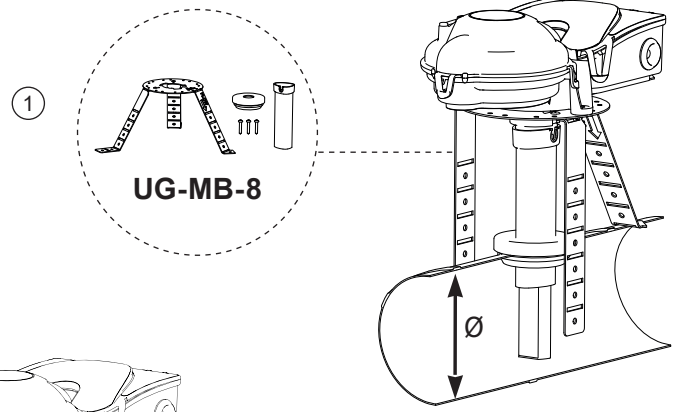

Ducts $\varnothing \geq 200$ mm (2/3 ft)

1. For all ducts with a hydraulic diameter of 200 mm (2/3 ft) or larger, the UG8 can be mounted directly on the duct.
2. If the duct is insulated, use mounting bracket UG-MB-8.

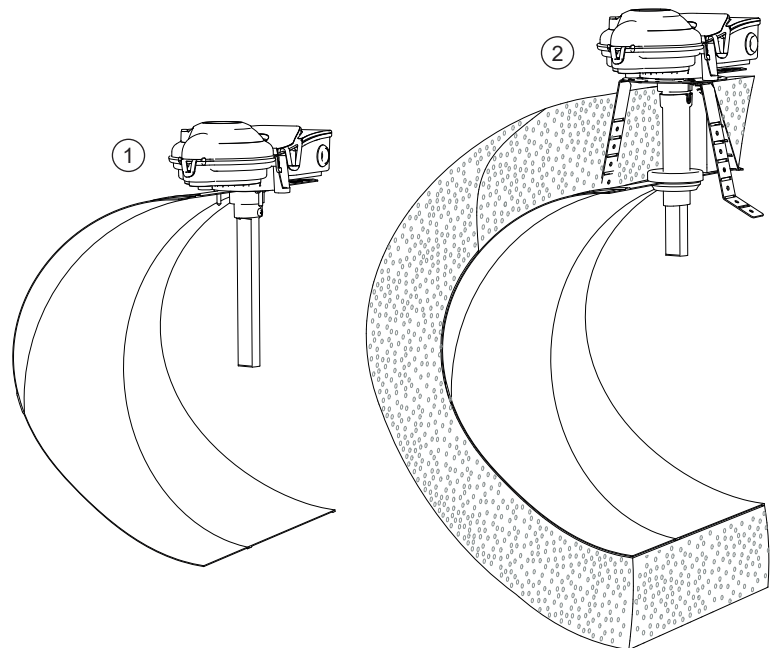

2

Drill a hole in the duct

Without mounting bracket, $\varnothing 38$ mm (1.5")

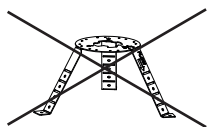

With mounting bracket, $\varnothing 51$ mm (2")



8

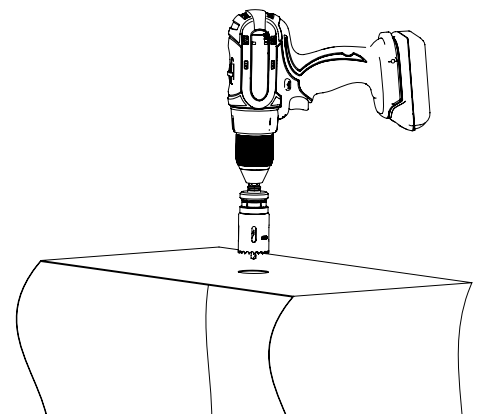

3

Mount the sampling tube and the rotation part

1. Insert the sampling tube into the bottom of the rotation part.
2. Secure it with the locking screw.
3. Turn the rotation part in the correct air-flow direction, so that the white FLOW-arrow and the air-flow direction of the duct correlate.
4. Fix the rotation part to the ventilation duct according to the illustration.

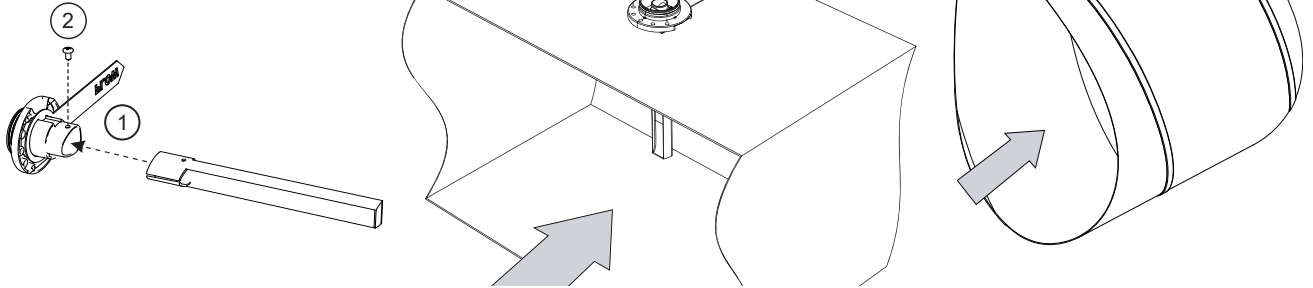

4

Installation on the duct

1. Mount the Uniguard on the rotation part and rotate it to a desired direction.
2. Secure the Uniguard with the two screws.

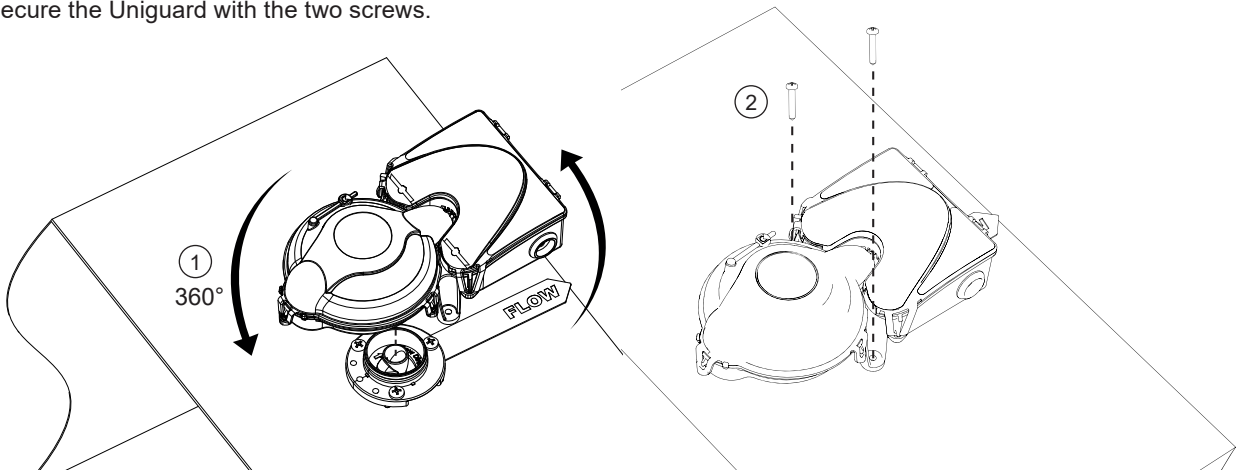

5

Electrical installation

1. Remove the cover over the connection housing by gently releasing the snap locks. Uniguard 8 has two pre-mounted IP67 approved glands for cable diameter 4-11 mm, type Klikseal.

NOTE! The cable must only be pulled through the Klikseal in one direction: into the Uniguard. To exchange a mounted cable, cut the cable outside of the Uniguard and pull out the rest from the inside.

2. Connect the cable wires according to the wiring diagram, inside the cover. The relay outputs are shown in power off/alarm condition. For complete technical product information, see the product data sheet.

Wiring diagram: UG8-E and UG8-Z models

Wiring diagram: UG8-O

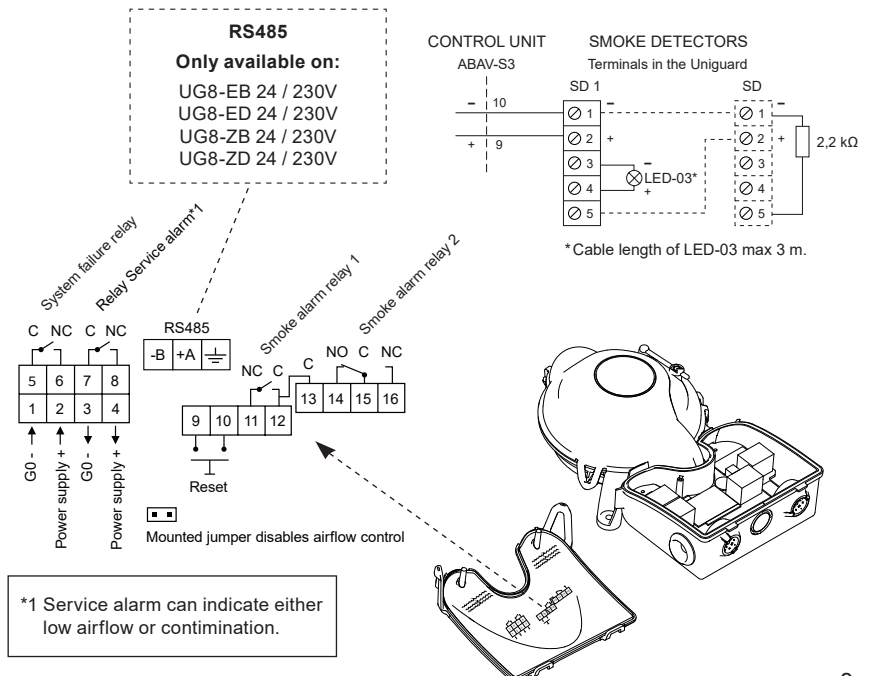

6

Test of detector

1. Check the detector with smoke detector aerosol test spray (e.g. SOLO A5).
2. Move the "test hole plug" to the side and briefly release a spray of aerosol.

When alarming the LED lits red on the detector and when service alarming (contamination) it lits yellow.

IMPORTANT!

Reassemble the "test hole plug".



Do not drill any holes in the cover for signs etc. Holes will cause air leakage and seriously disturb the function of the detector.

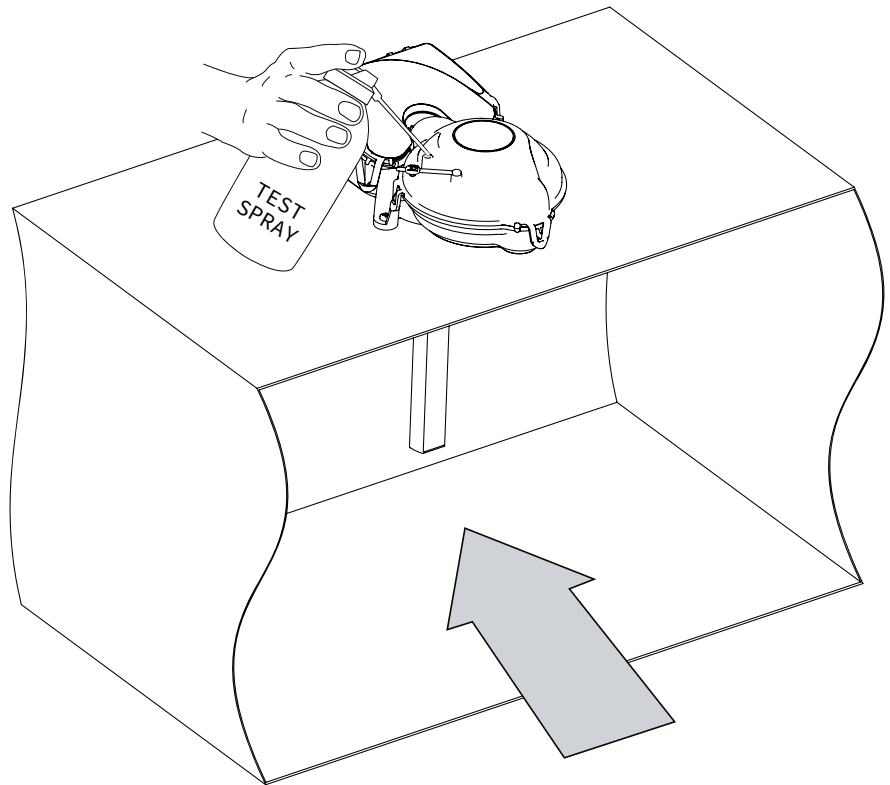

7

Mounting in places where possible condensation problems could arise, e.g. cold attics.

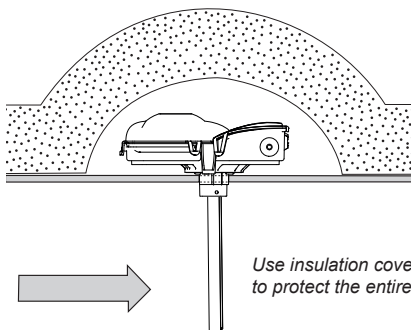

Use insulation cover of 100-200 mm (4-8") to protect the entire Uniguard.

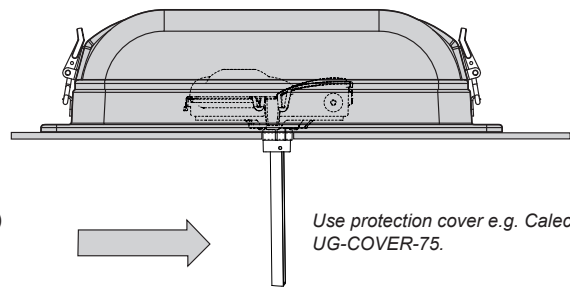

Use protection cover e.g. Calectro's UG-COVER-75.

A sign should be used to show location of the detector.

For UG8-O: A remote LED alarm indication is recommended when the Uniguard is hidden.

8

Mounting bracket for insulated ducts and ducts smaller than 200 mm (2/3 ft).

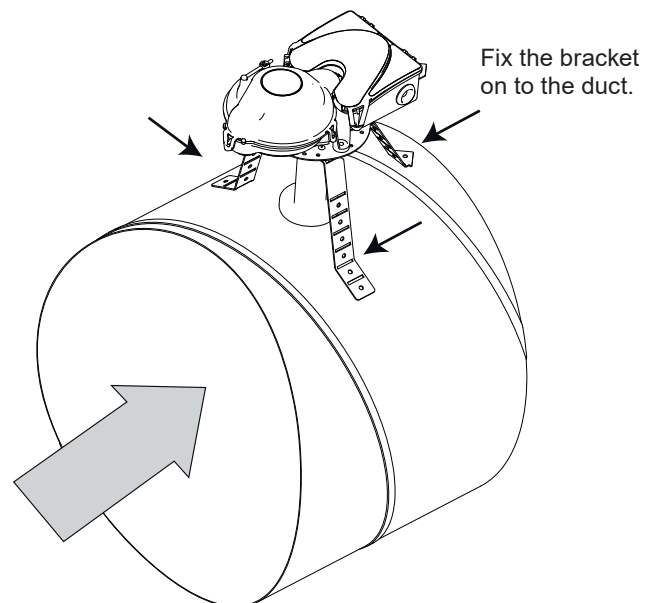
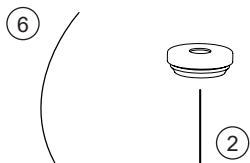
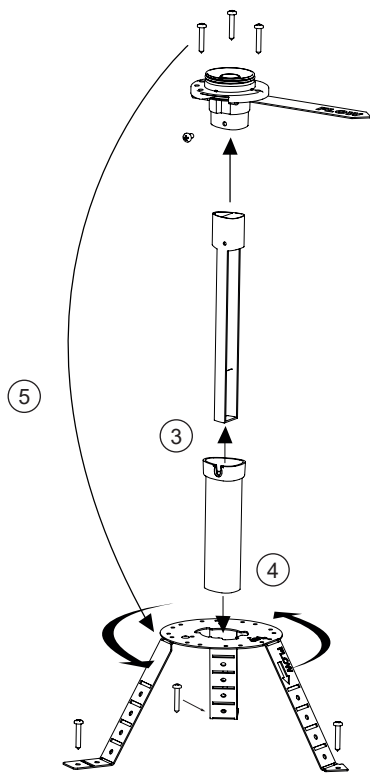
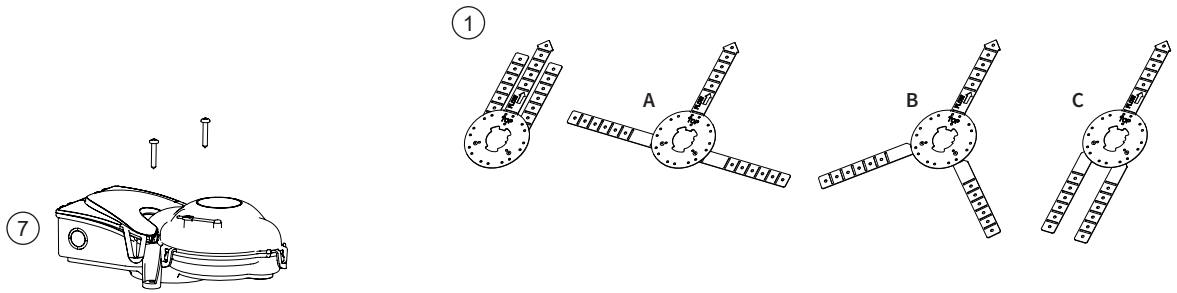

1. The mounting bracket is supplied flat. Shape the mounting bracket in position A, B or C. The mounting bracket can then easily be bent to fit circular or rectangular ducts.
The position of the legs of the mounting bracket will be locked with the mounting screws from the rotation part.
2. Drill a hole \varnothing 51 mm (2") and mount the rubber gasket.
3. Mount the sampling tube and sleeve. Fix them with the locking screw.
4. Insert the sampling tube into the mounting bracket. Make sure the flow arrows are in the same direction.
5. Fix the rotation part and lock the legs with the three screws.
6. Mount the bracket in the correct air flow direction on the duct and fix it with the three screws.
7. Mount the uniguard on the rotation part and fix it with the two screws.

9
**Information for UG8 models with Bluetooth communication
UG8-EB-24, UG8-EB-230, UG8-ZB-24 and UG8-ZB-230**
Uniguard with Bluetooth and Modbus

UG8-EB and UG8-ZB comes with Bluetooth communication capabilities. Using the mobile APP (CALECTRO ASSISTANT), available on both iOS and Android, detector status, contamination value and low airflow alarms can be viewed. The same information is also available using Modbus RTU. The settings for Modbus communication can be set using the push button and these are shown in the APP.

For more information, please read Modbus communication.

CALECTRO ASSISTANT App

To use the mobile app the bluetooth needs to be turned on, on the mobile device. DO NOT try to pair the mobile device with the UG8. Enter the app and the UG8-bluetooth units close by will appear there.

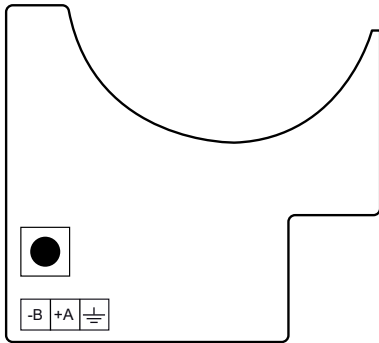
Raised circuit board

Modbus communication

On the raised circuit board, there is a settings button, which is used to configure the Modbus communication.

Start the CALECTRO ASSISTANT app and find the UG8 that needs to be set up, via MODBUS Settings under Device details. Press and hold down the settings button on the UG8 for approximately two seconds to enter the setup. The communication settings are shown in the app. A “short” press changes the communication setting. There are 12 different options. Press and hold down the button for approximately two seconds to confirm the choice. Under Address, the Modbus-ID is displayed. A “short” press switches (increments) the address. There are 64 different options. Press and hold down the button for approximately two seconds to confirm the address settings.

Please note that both the communication settings and the address must be confirmed within 10 seconds for them to be saved. If this is not done, both the communication setting and the address will revert to their previous setting.

Modbus connection

The Modbus connection is made via three terminal blocks on the circuit board.

From left:

1. -B
2. +A
3. GND

10

Information for UG8 models with display UG8-ED-24, UG8-ED-230, UG8-ZD-24 and UG8-ZD-230

Uniguard with display and Modbus

The UG8-ED/UG8-ZD has a display showing the detector's contamination level as a percentage. When the detector activates service/contamination alarm, "SA" appears on the display instead of a percentage.

Displays abbreviations:

- "AL" = Smoke alarm
- "LF" = Low airflow alarm
- "SA" = Service/contamination alarm
- "--" = System failure/detector removed

Only on UG8-ZD-24 and UG8-ZD-230:

- "AL" (flashing) = "Alarm memory"
- "CL" = Reset "Alarm memory" completed

Modbus RTU communication (read only)

Using Modbus, detector status, contamination value and low air flow alarms can be viewed.

Communication settings are set using the push button located on the right-hand side of the display. For more information, please read Modbus communication.

Raised circuit board

Example image shows current contamination value in percentage (00%).

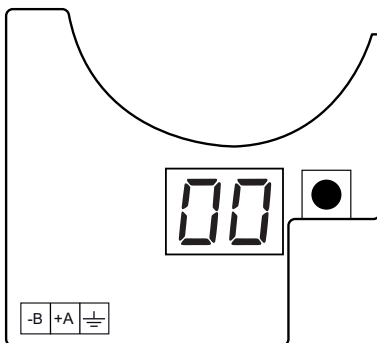

Modbus communication

To the right of the display on the raised circuit board, there is a push button, which is used to configure the Modbus communication.

Press and hold down the button for approximately two seconds to enter the setup. The current communication (.0 to .b) is shown first, flashing. A "short" press changes the communication setting. There are 12 different options. See the table Communication settings. Press and hold down the button for approximately two seconds to confirm the choice. Now, the address (ID) that has been set (1-64) is shown instead. A "short" press switches (increments) address. There are 64 different options. Press and hold down the button for approximately two seconds to confirm the address settings.

Please note that both the communication settings and the address must be confirmed within 10 seconds for them to be saved, after which [--] is shown on the display. If this is not done, both the communication setting and the address will revert to their previous setting.

Modbus connection

The Modbus connection is made via three terminal blocks on the circuit board.

From left:

1. -B
2. +A
3. GND

Communication settings

Communication settings	Baud rate	Parity	Number of stop bits
.0	9600	None	1
.1	9600	None	2
.2	9600	Even	1
.3	9600	Odd	1
.4	19200	None	1
.5	19200	None	2
.6	19200	Even	1
.7	19200	Odd	1
.8	38400	None	1
.9	38400	None	2
.A	38400	Even	1
.b	38400	Odd	1

11

Modbus register

Discrete inputs (1x)	Function	Value range	Read / Write
1x0001	Installed detector	0 or 1	R
1x0002	Smoke alarm	0 or 1	R
1x0003	Service alarm	0 or 1	R
1x0004	Low airflow alarm	0 or 1	R
1x0005	Contamination value	0 to "service alarm"	R

Holding reg. (4x)	Function	Value range	Read / Write
4x0001	Installed detector	0 or 1	R
4x0002	Smoke alarm	0 or 1	R
4x0003	Service alarm	0 or 1	R
4x0004	Low airflow alarm	0 or 1	R
4x0005	Contamination value	0, to "service alarm"	R
4x0007	Manual relay control	0/1234 (*1)	R/W
4x0008	Alarm reset	0/1234 (*2)	R/W

(*1) "0" sets the smoke alarm relays in normal operating status, "1234" sets the smoke alarm relays in alarm status.

(*2) "1234" resets the smoke detector, then the value goes automatically back to "0".

12

In case you need to replace the smoke detector

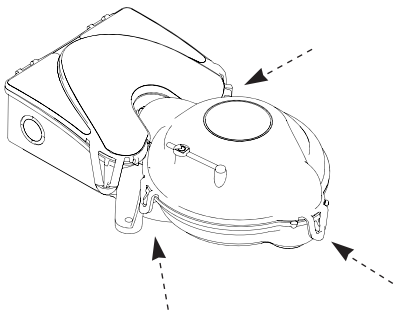

1. Remove the cover by gently bending the snap locks outwards.

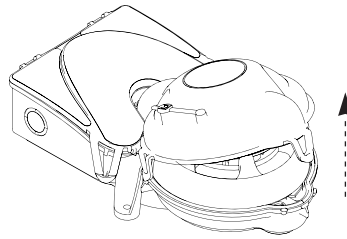

2. Detach the cover.

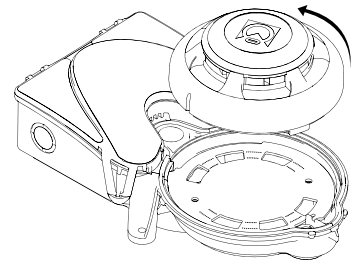

3. Remove the smoke detector by rotating it counterclockwise approximately 1/5 turn.

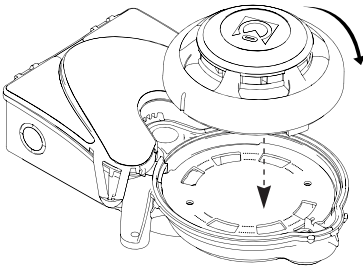

4. Insert the new detector and rotate it clockwise.

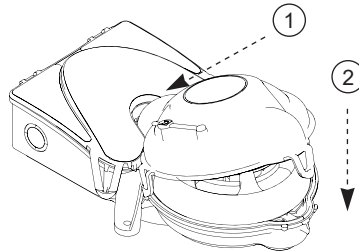

5. Reattach the cover.
(1) Start by placing the "lip" of the cover in the cavity next to the air inlet.
(2) Then press down the cover.

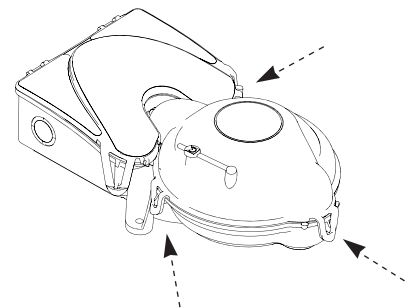

6. Check that all three snap locks are properly pressed in place.

FINAL CHECKS

- Check that the rotation part of the Uniguard is correctly installed according to the air flow in the duct.
- Check that the plastic plug of the test hole is properly installed.
- It is recommended that smoke from a smoke generator is introduced into the duct to check the detector's function.

Trouble shooting

The smoke detector indicates alarm without smoke.

- Smoke detector is faulty or contaminated. The detector needs to be replaced.



According to WEEE (Waste of Electrical and Electronic Equipment) directive, you must at the end of life of the product dispose of it separately at an appropriate collection point and not place it with unsorted waste. Alternatively return it to Calectro for recycling.

03.02606250