



ENGLISH

Room controller for CO₂, temperature and humidity (%RH).

INDEX

1. Technical data
2. Function
 - Applications 1-5: VAV, heating and cooling control
 - Applications 8-11: VAV control with basic ventilation
 - Applications 6-7: Transmitter function and digital output-on/off
 - Applications 12-14: VAV, heating and cooling control
 - Application 15: Control function
 - Adjustment of preset applications (via MODBUS RTU)
 - PWM outputs
 - Service mode (DIP setting for push-button. Also via MODBUS)
 - Temperature adjustment
 - CO₂ calibration with fresh air
 - LED indications on the circuit board
 - MODBUS communication (RTU / RS485)
3. Use
4. Installation
5. Maintenance
6. Figures
7. Application table
8. Modbus register (separate document)

1. TECHNICAL DATA

Supply voltage:	24V AC/DC
Power Consumption	22mA (avg.) 56mA (max.)
Outputs:	
Analogue Out 1:	0-10V
Analogue Out 2:	0-10V
Analogue Out 3:	0-10V or PWM
Analogue Out 4:	PWM period 2 sec.
Max load on 0-10V outputs:	>5 kΩ imp.

Max load on PWM: 1A (24V)

Digital input: 1 pcs

LED indications

Yellow (L1), continuous light:

Operation

Green (L2):

See detailed description under "LED indications on the circuit board".

Red (L3):

See detailed description under "LED indications on the circuit board".

Too low supply voltage, too high load of outputs and blink indication when changing application. Lights up continuously in service mode. Fresh air calibration (400 ppm) of CO₂ measurement value. Offset adjustment of temperature measurement value +/- 3°C (resolution 0.2).

Screw terminals: 10 wires of 2,5 mm

Flat-blade screwdriver: 2.5 x 0.5 mm

Dimensions WxHxD: 92 x 92 x 28,5 mm

Weight: 105 grams

Protection class: IP20

2. FUNCTION

CRC-A-MB-24 is a room controller for controlling ventilation, heating, cooling and humidity.

The CO₂ sensor in the CRC-A-MB-24 is maintenance-free in normal environments thanks to the built-in self-correcting ABC algorithm. This means that our sensors have an expected lifetime of at least 15 years and do not require any additional calibration when used in normal indoor air applications.

The desired function is set via a DIP switch. There are 15 pre-programmed functions/applications to adapt the CRC-A-MB-24 to most requirements for room control of CO₂, temperature and humidity. The list in section 7 shows all pre-programmed settings. Some settings are similar, but e.g. the p-band for temperature is different so as to make CRC-A-MB-24 easily configurable for different requirements. The digital input has different functionality depending on the selected application/setting, and can be activated both physically and via MODBUS. All preset functions are fully adjustable via MODBUS RTU.

To check the function of the installation/system, the respective measurement values for CO₂, temperature and humidity can be simulated manually, via MODBUS.

The CRC-A-MB-24 is supplied factory set in application 1 (VAV, heating and cooling control).

Preset applications/functions

- Appl. 1-5 VAV, heating and cooling control
- Appl. 6-7 Transmitter function and digital output-on/off
- Appl. 8-11 VAV control with basic ventilation
- Appl. 12-14 VAV, heating and cooling control
- Appl. 15 Control function

Applications 1-5

VAV, heating and cooling control

Applications 1-5 are all usable for VAV, heating and cooling control. Analogue output 1 (0-10V) is affected by the measured values of CO₂, temperature and humidity and the output voltage is controlled by the highest measurement value.

Analogue output 2 (0-10V) is only affected by CO₂ measurement value.

Analogue output 3 (0-10V or PWM) is only affected by temperature measurement value.

Output 4 (PWM) is affected by different measurement values, see table.

The digital input (closure) gives 10V output on analogue output 1. When the digital input is opened, an afterrun time of 10 minutes starts. The afterrun time can be changed via MODBUS.

Applications 6-7

Transmitter function and digital output-on/off

These applications are mainly used if you only want to measure CO₂, temperature and humidity.

Analogue output 1 (0-10V): P-band, CO₂ 500-1500ppm in appl. 6 and 0-2000ppm in appl. 7.

Analogue output 2 (0-10V): P-band for both applications, temperature 0-50°C.

Analogue output 3 (0-10V): P-band for both applications, humidity 0-100%RH.

Output 4 (OFF/ON): CO₂ 900/1000ppm in appl. 6 and 800-900ppm in appl. 7.

Applications 8-11

VAV control with basic ventilation

These applications have similar functions to applications 1-5, but analogue output 1 (0-10V) is locked at 20% until the digital input is closed. This provides a fixed basic ventilation until the VAV control is activated by, for example, a motion detector or timer. When digital input is opened, an afterrun time of 10 minutes starts, and then analogue output 1 returns to a locked output signal of 20%.

Applications 12-14

VAV, heating and cooling control

These applications have similar functions to applications 1-5, but with different P-bands, see table.

Application 15

Control function

This application provides 100% output signal on all outputs when the digital input is closed. The function can be used to check the installation. No adjustment is in progress.

Adjustment of preset applications (via MODBUS RTU)

All preset applications can be adjusted according to your own wishes via the MODBUS communication. For example, the P-band for the CO2 or temperature control can be changed to adapt to a specific function.

There are two different ways to choose which preset application to adjust:

Option 1. Set the DIP switches DIP2:1-4 to the desired application and carry out the adjustments via the MODBUS register. After all changes are made, "save function" in the MODBUS register should be activated. The new setting is saved "non-transient" in application zero (DIP switches DIP2:1-4 set to OFF).

Option 2. Set the DIP switches DIP2:1-4 to the OFF position (application zero) and select in the MODBUS register which preset application to adjust. After all changes are made, "save function" in the MODBUS register should be activated. The new setting is saved "non-transient" in application zero (DIP switches DIP2:1-4 set to OFF position) As factory set, application 1 is in the DIP setting for application zero.

The preset applications (1-15) can never be lost via adjustments in the MODBUS register because the changes are saved in application zero. That is, in the position when the DIP switches DIP2:1-4 are set to the OFF position.

Adjustments via MODBUS in the CRC-A-MB-24 can therefore be made even before the room controller is installed.

If there is MODBUS RTU communication where the room controller is to be installed, adaptations can also be made via remote communication. In this case, DIP2:1-4 is already set to OFF during installation, in order to be able to directly use the adaptation, and it is saved in the non-transient memory.

PWM outputs

The PWM (Pulse Width Modulation) outputs in the CRC-A-MB-24 provide different output voltages depending on whether the product is powered by 24V AC or DC. Since CRC-A-MB-24 has a half-wave rectification, the PWM voltage will be about 13V with AC supply and about the same as the supply voltage with DC supply.

The component to be PWM-controlled is connected between G+ (terminal 1) and the PWM output (terminal 5 and/or 6).

To activate the PWM function on output 3, the programming jumper is moved from position "0-10V" to position "PWM" on the pin strip next to the terminal blocks.

Service mode

(The service mode can also be reached via MODBUS)

In the service mode, the CO2 sensor can be fresh air calibrated. The temperature sensor measurement value can also be adjusted in parallel to adapt to the conditions where CRC-A-MB-24 is placed.

These adjustments are performed via the push button on the circuit board (marked B1) or via MODBUS. In normal operating mode, B1 is disconnected.

The service mode is activated via DIP switch. Via DIP switch 1, Dip 8 is set to ON. This activates the service mode, which is indicated by the red LED (L3) lighting up. Via DIP switch 2, Dip 8 is selected if CO2 or temperature is to be handled.

Via MODBUS, adjustments can be made regardless of DIP setting.

Service mode on or off is set by DIP switch 1, Dip 8:

DIP switch 1	Normal operation	Service mode!
Dip 8	OFF	ON

Choice of adjustment/calibration of Temp or CO2, with Service mode:

DIP switch 2	Temp	CO2
Dip 8	OFF	ON

Temperature adjustment

Set DIP2:8 to the OFF (yellow and red LED lights up) position for offset adjustment of the temperature measurement as follows:

Adjustment range +/- 3°C in 0.2°C increments. With each press of the button, the measured value is increased by 0.2°C until the measurement value is increased by +3.0°C. At the next press, the measurement value is lowered to -3.0°C, then -2.8, -2.6 etc.

Each button press is indicated by the yellow LED (L1) turning off.

To reset to the original reading, press and hold the push button for more than 10 seconds, until L1 starts flashing rapidly.

This scale adjustment can also be done via MODBUS.

CO2 calibration with fresh air

Set DIP2:8 in the ON (red LED lights up) position for calibrating the CO2 sensor.

In this position, L1 is off and button pressing is indicated by L1 lighting up.

Air out the room so that the CRC-A-MB-24 is only exposed to fresh air. **Avoid breathing directly onto the product.**

Perform the fresh air calibration by briefly pressing the push button. Now the measurement value is changed to 400ppm, which is the normal CO2 concentration in fresh air.

Zero calibration of the CO2 sensor (requires access to non-CO2 gas, e.g. nitrogen,) should only be performed by specially trained personnel.

LED indications on the circuit board

The LEDs have different indication functions in normal operating mode and in service mode.

Normal operating mode:

LED - normal operating mode	Indication	Description
Green (L2)	Off	CRC-A-MB-24 turned off
Green	Steady light	Operation indication
Green	Flashing	MODBUS communication
Yellow (L1)	Steady light	Digital input function activated
Yellow	Flashing	Delay time in progress
Yellow	Off	Digital input function inactive
Red (L3)	Off	Normal operating mode without alarm
Red	Flashes 2 pulses	Alarm indication overload of any analogue output
Red	Flashes 3 pulses	Alarm indication any analogue output short circuited
Red	Flashes 4 pulses	Alarm indication for low supply voltage

LED - service mode	Indication	Description
Green	-	Same function as in normal operating mode
Red	Steady light	Indicates service mode
Yellow	Steady light	Temperature adjustment mode
Yellow	Turns off once per "short/quick" button press	Temperature adjustment 0.2K
Yellow	Quick flashing after button pressed for more than 10 seconds, in temperature adjustment mode	Zeroing of temperature adjustment made
Yellow	Off	CO2 calibration mode
Yellow	Flashes once per "short/quick" button press	Starts CO2 fresh air calibration, target value 400ppm
Yellow	Quick link after button pressed for more than 10 seconds, in CO2 calibration mode	Starts CO2 zero calibration: only by authorised staff at the supplier.
Yellow/Red	Quick flashing of both yellow and red LED after CO2 calibration.	Indicates that CO2 calibration has been performed.

MODBUS communication (RTU / RS485)

Communication settings are performed via the DIP switches.

Address (ID) is set in binary on DIP switch 1, Dip 1-5. Example:

DIP switch 1	ID 1	ID 16	ID 30
Dip 1	ON	OFF	OFF
Dip 2	OFF	OFF	ON
Dip 3	OFF	OFF	ON
Dip 4	OFF	OFF	ON
Dip 5	OFF	ON	ON

Baud rate is set on DIP switch 1, Dip 6-7:

DIP switch 1	9600	19200	38400	57600
Dip 6	OFF	ON	OFF	ON
Dip 7	OFF	OFF	ON	ON

The batch is set on DIP switch 2, Dip 6-7:

DIP switch 2	None, 2 stop	Odd, 1 stop	Even, 1 stop	None, 1 stop
Dip 6	OFF	ON	OFF	ON
Dip 7	OFF	OFF	ON	ON

For the complete Modbus table, please see separate Modbus register.

3. USE

CRC-A-MB-24 is used for CO₂, temperature and humidity control of indoor environment.

4. INSTALLATION

CRC-A-MB-24 is installed on the wall of the room to be controlled. Avoid installation in direct sunlight or near heat or cooling sources. If it is installed over a junction box/cable pipe, these must be sealed to avoid affecting measurement results. Screws with specially adapted head size are attached.

5. MAINTENANCE

CRC-A-MB-24 is normally maintenance-free. The CO₂ sensor in the controller is maintenance-free in normal environments thanks to the built-in self-correcting ABC algorithm. Calibration and adjustment of CO₂ and temperature readings can either be performed via push button on the circuit board or via MODBUS.

6. FIGURES

FIG. 1 Wiring diagram

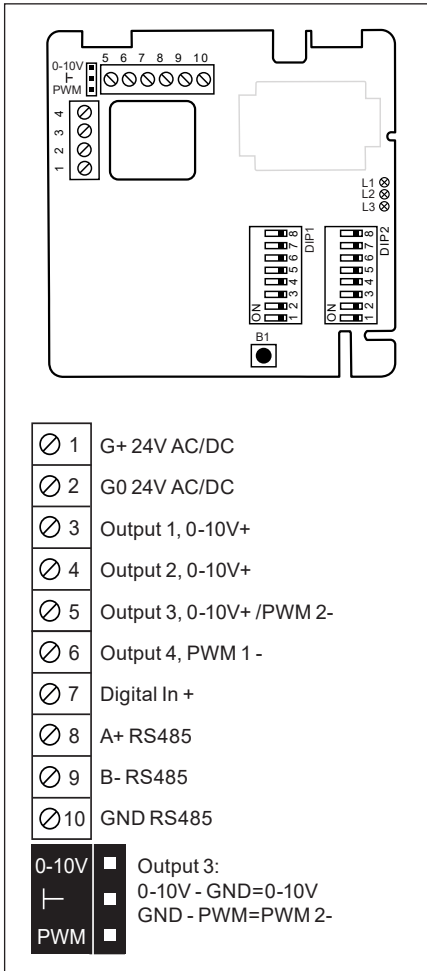

FIG. 2 Removing the cover

Remove the cover by gently pressing in the two locking hooks on the top of the enclosure. For example, use a small screwdriver to reach into the locking hooks between the air grilles. Be careful not to damage electronic components on the inside.

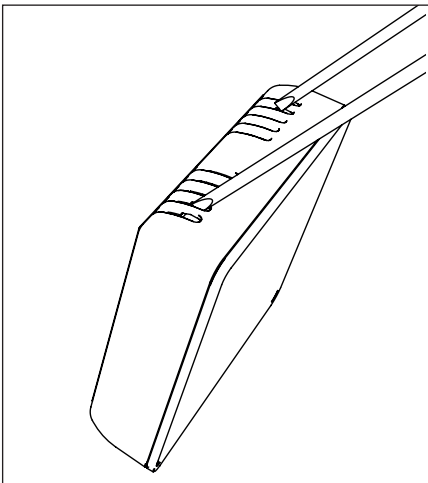

FIG. 3 Wall installation

Use the attached screws, the heads of which are adapted so as not to damage components on the circuit board.

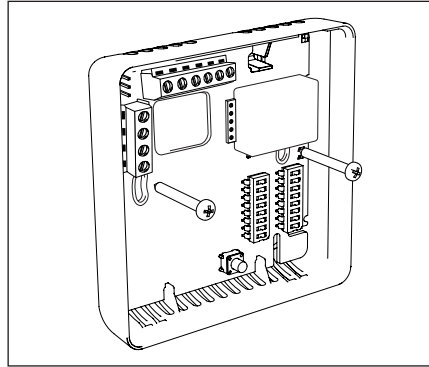
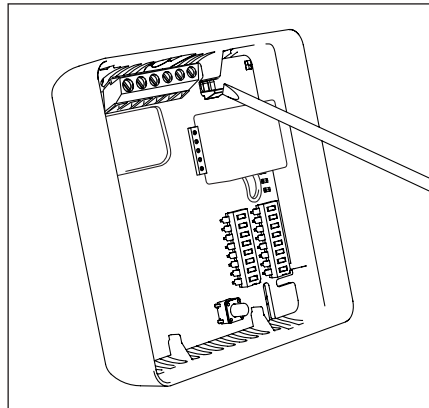

FIG. 4 Remove the circuit board from the enclosure

The circuit board is held in place in the enclosure by a snap lock. Gently bend the snap lock upwards to release the circuit board. Be careful not to damage electronic components.



7. APPLICATION TABLE

The list below shows all pre-programmed settings.

Application	Output	CO2 ppm	Temp C	Humidity %	Digital input sets output to xxx%	Output function	Note
1	1	600-900	22-23	75-85	ON=100%	Afterrun time 10 min	Largest signal controls
	2	0-2000			No effect		Measuring signal CO2
	3		0-50		No effect		Measuring signal temperature
	4	900/1000			No effect		OFF/ON
2	1	600-900	22-23	75-85	ON=100%	Afterrun time 10 min	Largest signal controls
	2	600-900			No effect		Air quality function
	3		23-24		No effect		Cold function
	4		20-19		No effect		Heat function
3	1	600-900	22-23	75-85	ON=100%	Afterrun time 10 min	Largest signal controls
	2	600-900			No effect		Air quality function
	3		23-24		No effect		Cold function
	4		21-20		No effect		Heat function
4	1	500-1000	21-23	75-85	ON=100%	Afterrun time 10 min	Largest signal controls
	2	0-2000			No effect		Measuring signal CO2
	3		21-20		No effect		Heat function
	4	700/900			No effect		OFF/ON
5	1	600-900	21-22	75-85	ON=100%	Afterrun time 10 min	Largest signal controls
	2	600-900			No effect		Air quality function
	3		22-23		No effect		Cold function
	4		20-19		No effect		Heat function
6	1	500-1500			No effect		Air quality function
	2		0-50		No effect		Measuring signal temperature
	3			0-100	No effect		Measuring signal relative humidity
	4	900/1000			No effect		OFF/ON
7	1	0-2000			No effect		Measuring signal CO2
	2		0-50		No effect		Measuring signal temperature
	3			0-100	No effect		Measuring signal relative humidity
	4	800/900			No effect		OFF/ON
8	1	600-900	22-23	75-85	OFF=20%	Afterrun time 10 min, ON = output adjusts	Largest signal controls
	2	600-900			No effect		Air quality function
	3		23-24		No effect		Cold function
	4		20-19		No effect		Heat function
9	1	600-900	22-23	75-85	OFF=20%	Afterrun time 10 min, ON = output adjusts	Largest signal controls
	2	600-900			No effect		Air quality function
	3		23-24		No effect		Cold function
	4		21-20		No effect		Heat function
10	1	500-1000	21-23	75-85	OFF=20%	Afterrun time 10 min, ON = output adjusts	Largest signal controls
	2	0-2000			No effect		Measuring signal CO2
	3		21-20		No effect		Heat function
	4	700/900			No effect		OFF/ON

Application	Output	CO2 ppm	Temp C	Humidity %	Digital input sets output to xxx%	Output function	Note
11	1	600-900	21-22	75-85	OFF=20%	Aferrun time 10 min, ON = output adjusts	Largest signal controls
	2	600-900			No effect		Air quality function
	3		22-23		No effect		Cold function
	4		20-19		No effect		Heat function
12	1	600-900	21-22	75-85	ON=100%	Aferrun time 10 min	Largest signal controls
	2		22-23		No effect		Cold function
	3		20-19		No effect		Heat function
	4	500/600			No effect		OFF/ON
13	1	600-900	22-23	75-85	ON=100%	Aferrun time 10 min	Largest signal controls
	2		23-24	75-85	No effect		Cold function
	3		20-19	75-85	No effect		Heat function
	4	500/600			No effect		OFF/ON
14	1	500-800	22-23	75-85	ON=100%	Aferrun time 10 min	Largest signal controls
	2	700-1000	22-23	75-85	No effect		Largest signal controls
	3	1000-1200	22-23	75-85	No effect		Largest signal controls
	4	1300/1500			No effect		OFF/ON
15	1				ON=100%		Control application
	2				ON=100%		Control application
	3				ON=100%		Control application
	4				ON=100%		Control application
0	1						Adjustable application configured via Modbus
	2						Adjustable application configured via Modbus
	3						Adjustable application configured via Modbus
	4						Adjustable application configured via Modbus

Application is set on DIP switch 2, Dip 1-4:

Application	Dip 1	Dip 2	Dip 3	Dip 4
1	ON	OFF	OFF	OFF
2	OFF	ON	OFF	OFF
3	ON	ON	OFF	OFF
4	OFF	OFF	ON	OFF
5	ON	OFF	ON	OFF
6	OFF	ON	ON	OFF
7	ON	ON	ON	OFF
8	OFF	OFF	OFF	ON

Application	Dip 1	Dip 2	Dip 3	Dip 4
9	ON	OFF	OFF	ON
10	OFF	ON	OFF	ON
11	ON	ON	OFF	ON
12	OFF	OFF	ON	ON
13	ON	OFF	ON	ON
14	OFF	ON	ON	ON
15	ON	ON	ON	ON
0	OFF	OFF	OFF	OFF

Properties of the outputs

Output 1 Analogue 0-10V Largest signal controls.

Output 2 Analogue 0-10V Largest signal controls.

Output 3 Analogue 0-10V or PWM is selected via jumper, Largest signal controls.

Output 4 PWM or 0/24V half-wave rectified voltage, minus (-).