

UG-3-O UNIGUARD SUPERFLOW

Optical smoke detector with service alarm for duct installation.



TECHNICAL DATA

Operating Voltage:	24V DC from control unit
Detector type:	Optical
Operating current:	~ 0,04 mA
Service alarm current:	~ 10 mA (at 22V)
Fire alarm current:	~ 40 mA (at 22V)
Operating temperature:	-10°C to +55°C
Maximum humidity:	99% RH
Duct air velocity range:	Approx. 0,2 to 20 m/s
Approvals	
UG-3-O:	VdS (Germany)
Detector head:	EN 54-7
LED on smoke detector:	Green - service alarm Red - smoke alarm
LED on PCB:	Yellow - service alarm Red - smoke alarm
Adaptor housing:	ABS
Weight:	660g
Protection:	IP54
Air sampling pipe:	Aluminium, weight 400g.

The length of the venturi pipe shall be chosen based upon how wide the ventilation duct is. The venturi pipes are available in 3 lengths; 0,6, 1,5 and 2,8 m. When the ventilation duct is wider than 0,6 m (dia), the venturi pipe should penetrate the whole duct.

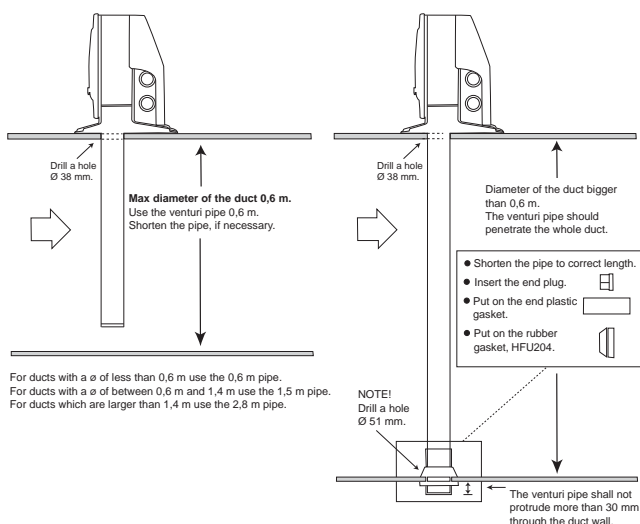

CHARACTERISTICS

- Patented venturi pipe and duct housing
- One-pipe air sampling system Uniguard Superflow
- New cross-section (shape) of the venturi pipe gives an optimum of venturi effect
- Service alarm
- Automatic sensitivity adjustment
- Test hole on cover
- Simple installation
- Sensitive flow indicator
- Simple service and maintenance
- Installer-friendly connection of cables
- Foolproof installation of venturi pipe

FUNCTION

Uniguard has been developed to detect smoke in ventilation ducts and combines a smoke detector and an adaptor system where both venturi pipe and housing are specially designed for optimum airflow through the smoke detector.

The Uniguard detector is designed to be used in ventilation systems with air velocities of 0,2m/s to 20m/s.

For smoke detection when the air handling unit is shut off or when there is limited air flow in the duct, a venturi pipe with a booster fan, VRF, is recommended.

Uniguard is used together with a control unit; e.g. ABAV-S3 to control fire-safety dampers, to stop ventilation fans, and to activate acoustic and optical alarms etc.

The detector has a bayonet fitting to simplify mounting and removal.

The detector UG-3-O contains an intelligent controlling circuit. This circuit is adjusting the sensitivity to give an optimal function during the whole life time of the detector. When the controlling circuit can no longer compensate for contamination, a service alarm is indicated.

For more information about the smoke detector, please see the data sheet for EVC-PY-DA.

Uniguard Superflow has 4 premounted IP67 approved cable entries with built-in cable anchorage for diameter 4-11 mm, type Klikseal.

BASIC PRINCIPLES FOR POSITIONING

For the airflow through the adaptor to be representative of the airflow in the ventilation duct, install the detector at a place where flow meters etc. normally are mounted, please see our installation instructions. You can also use your national or local rules for moutage according to "Methods for measuring airflow in ventilation systems".

UG-3-O UNIGUARD SUPERFLOW

Optical smoke detector with service alarm for duct installation.



INSTALLATION

The venturi pipe is made of aluminium and can easily be shortened to suit the diameter of the duct. Hole diameter is 38 mm. For insulated or circular ducts - use the mounting bracket, hole diameter is then 51 mm.

MAINTENANCE

When the detector becomes contaminated, sensitivity is increased, triggering the service alarm. This can be avoided for a considerable time by cleaning the detector once a year with a vacuum cleaner.

AIR FLOW MONITORING

The detector is fitted with a red plastic switch tongue. When the detector is correctly installed, the tongue is bent outwards by the air flow. The switch tongue provides a simple confirmation that there is no leakage and that the air flow from the duct is in fact flowing through the housing.

FUNCTION TEST

When installation is complete, the detector should be tested. This can be carried out with smoke or suitable aerosol testspray.

NB: When installing outdoors or in cold attics etc., where there is a risk for condensation, the detector should be insulated from the surrounding air with e.g. our weatherproof housing UG-COVER. In such cases it should also be marked with an extra indicator lamp, LED-03 and a sign marked "Hidden Detector".

VENTURI EFFECT

The new cross-section (shape) of the venturi pipe gives an optimum of venturi effect. The slots alongside the venturi pipe, for the inlet and the outlet of the venturi air stream, give maximum air flow and make the venturi pipe self-adjusting with a stable and uniform flow from the whole cross section of the ventilation duct.

ORDERING EXAMPLE

Item code	Designation
UG-3-O	Optical duct smoke detector

ACCESSORIES

Item code	Designation
UG-MB	Mounting bracket (for insulated/circular ducts)
UG-COVER	Waterproof housing (for mounting outdoors, in cold attics etc.)
VR-0.6M	Venturi pipe 0,6 m
VR-1.5M	Venturi pipe 1,5 m
VR-2.8M	Venturi pipe 2,8 m
VRF-0.6M	Venturi pipe 0,6 m with fan
VRF-1.5M	Venturi pipe 1,5 m with fan
VRF-2.8M	Venturi pipe 2,8 m with fan
ST-EXTEND	Extension of venturi tube VR & ST, 1.06M
ABAV-S3-GB-24V	Control unit 24V AC
ABAV-S3-GB-230V	Control unit 230V AC

DIMENSIONS

(mm)

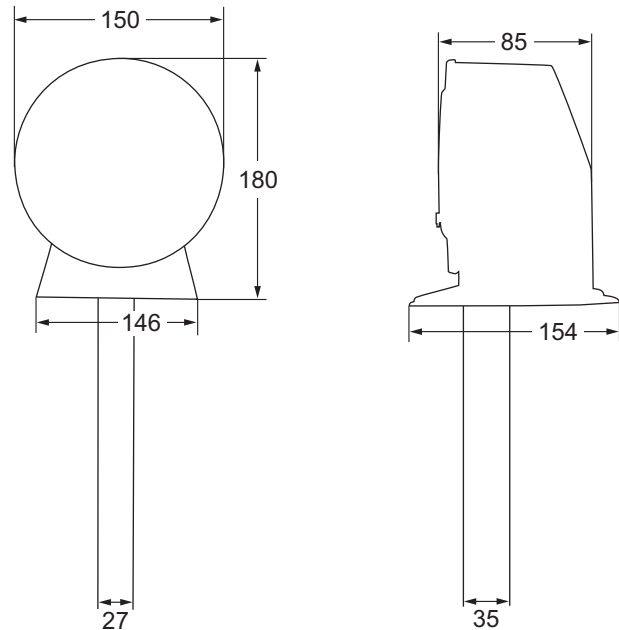

WIRING DIAGRAM

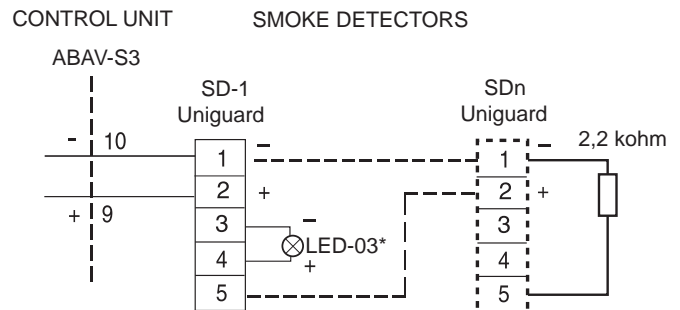

*Cable length to LED-03 max 3m.

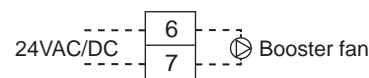

Terminal 6 and 7 can be used for installation of a venturi pipe with a booster fan.