

Installation Manual

A-SENSE-V, A-SENSE-V-D

CO₂ / temperature sensor with built-in general purpose controller

General

The IAQ-sensor product *A-SENSE-V* is used to measure indoor air carbon dioxide concentration and temperature. It is a very flexible controller with programmable outputs for both relay- and linear control of e.g. mixed air dampers, humidifier and fans. The measured values are shown on the display. The display version is also available for duct mounting.

The linear output functions are pre-programmed for different ventilation strategies for stand-alone control. The units can alternatively be connected to common VAV (Variable Air Volume) controllers, or Direct Digital Control (DDC). All functions can be modified from a PC with the RS232 A232 communication cable.



*A-SENSE-V-D for wall mounting and
UG3-A-SENSE-V-D for mounting in ventilation ducts*

Mounting instruction

Wall mounting of *A-SENSE-V*, see below.

Duct mounting of *UG3-A-SENSE-V-D*, please see separate mounting instruction.

For electrical installation, see page 4.

Dismounting of the sensor

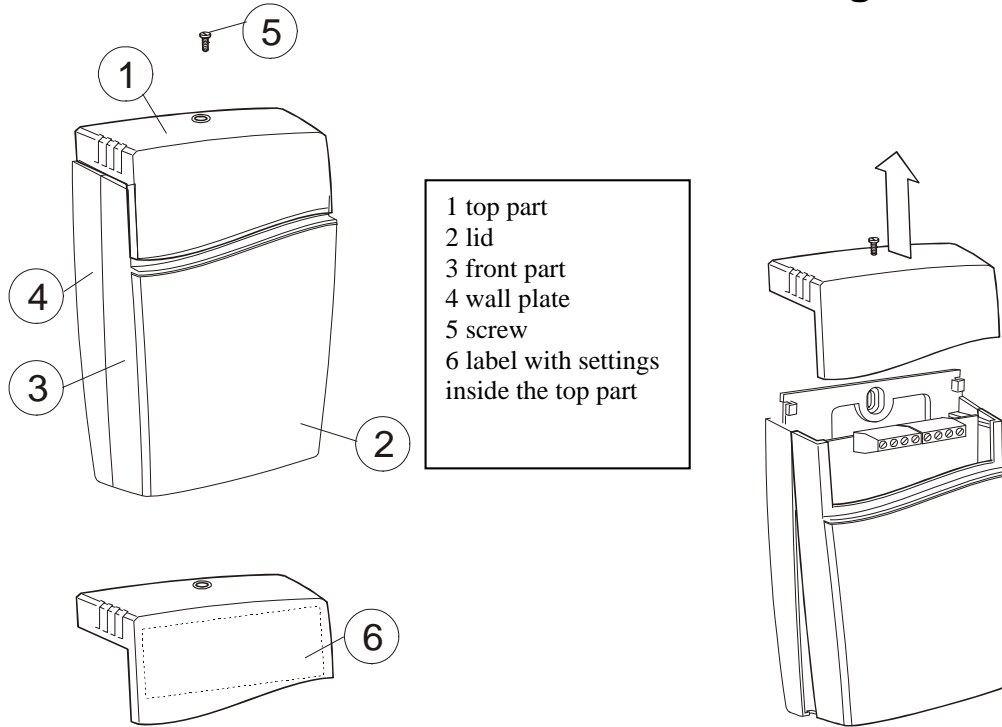

Pull the top part upwards

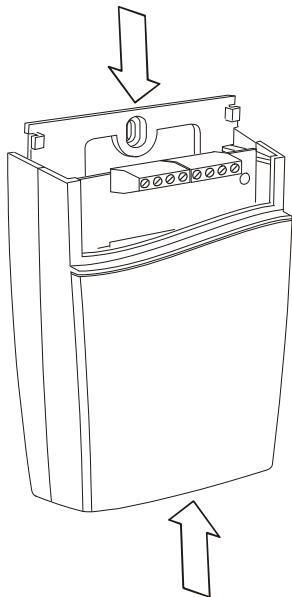

Push the front part with the lid upwards while keeping the wall plate steady

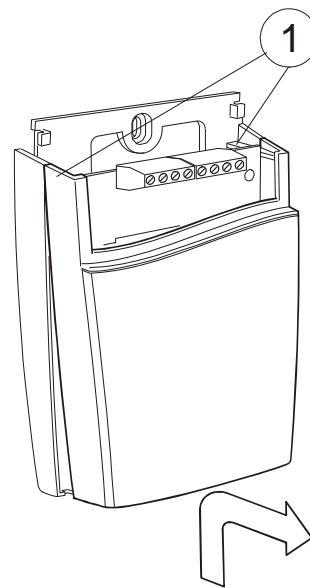

Fold the front part with the lid forwards and loose it from the hooks (#1)

Mounting of the sensor

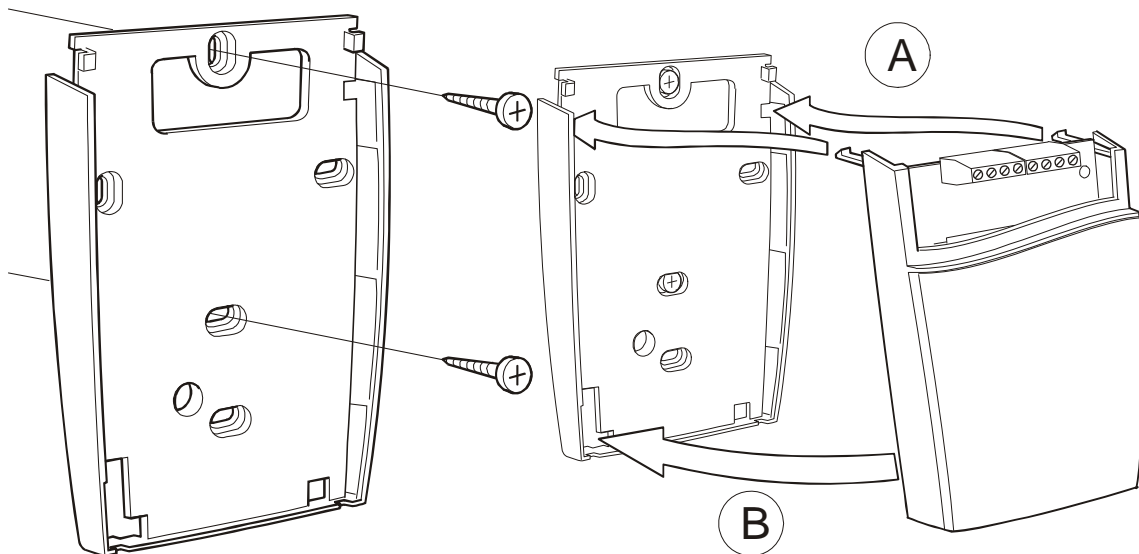

The wall plate is screwed onto the wall
The screw heads should be max 4 mm

(A) Put the top tabs of the front part into the top holes of the wall plate.
(B) Press the lower edge of the case onto the wall plate to latch

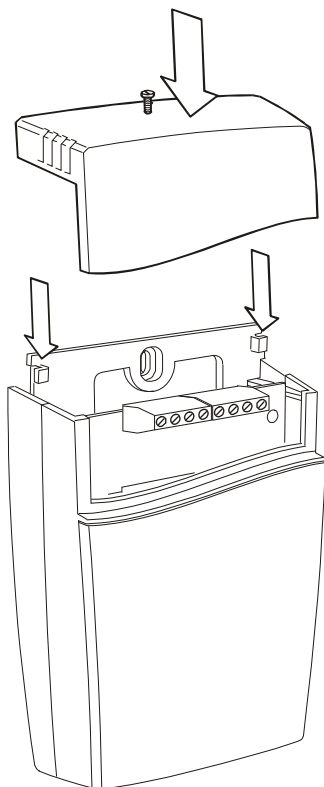

The top part is pushed under the locking hooks of the wall plate and is secured with a screw

Wall mounting

Mount the sensor on a wall which is not exposed to direct sunlight or airflow.

If mounting the sensor on a device box or conduits, they should be sealed to avoid airflow which can affect performance and accuracy of the sensor.



If for some reason the PCB must be removed it must be handled carefully and protected from electrostatic discharge! Normally, removing the PCB is not required.

Electrical connections

The power supply has to be connected to \sim and \perp . \perp is considered as system ground. The same ground reference has to be used for the aSENSE mill unit and for any connected device! Unless different transformers are used, special precautions need to be taken.

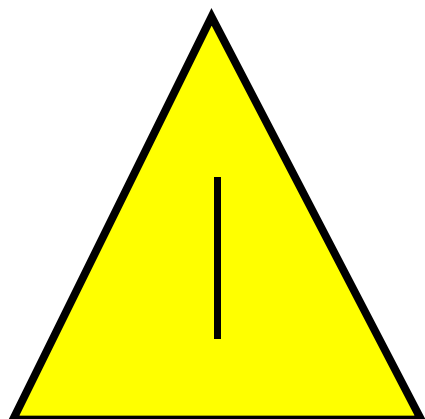

PLEASE NOTE!

The signal ground *is not* galvanically separated from the A-SENSE-V power supply!

NOTE!

The same ground reference has to be used for the A-SENSE-V unit and for any connected device!

If possible keep the sensor powered up after mounting. Connect the analogue output before measuring.

Connection Terminal	Function	Electrical Data	Remarks
\sim + \perp	Power (+) Power ground (-)	24 VAC/DC+ (+-20%), 3W 24 VAC/DC-	2W without output load See note 1!
Out(1) Out(2) 5 6	Analogue Output 1 (+) Analogue Output 2 (+) Signal Ground (-)	0-10 VDC or 0-20 mA, 2-10 VDC or 4-20 mA, Same as Output 1 Connected to \perp via PTC fuse	According to positions of OUT1 jumper and start point selection. See note 2! According to positions of OUT2 jumper and start point selection. See note 2! See note 1!
7	Normally open	Contact free relay minimum load 1mA/5V rated load 0,5A/125VAC; 1A/24VDC	Triggered by register OUT3
8 Out(4)	Analogue Output 4 (+) or Open Collector	0-10 VDC Max 0,5A, 55VDC / 40VAC (half-wave rectifier protection)	According to positions of OUT4. See note 2 & 3!
DI1	Digital Input 1	Closed contact current 1mA Open contact voltage max 5V	Do not apply any voltage on this input!

Table I. Electrical terminal connections for A-SENSE-V(-D)

Note 1: The ground terminal is used as negative power supply DC input or AC phase ground \perp (halfwave rectifier). The signal ground M, protected by a PTC resistor, is the same as power ground \perp (permitting a "3-wire" configuration). A single transformer may be used for the entire system.

Note 2: A-SENSE-V can deliver both a voltage or a current loop for OUT1/OUT2. For OUT4 a voltage output or an open collector output is selected with jumper OUT4. To change between voltage and current output mode the hardware jumpers are used. There is one jumper for OUT1 and one for OUT2, so that one output can be a voltage output and the other a current output. Both, voltage output and current output, can have start points 0 % (0-10 VDC or 0-20mA) or 20% (2-10 VDC or 4-20mA) selected from PC software.

Note 3: Current of Open Collector is internally returned to \perp terminal.

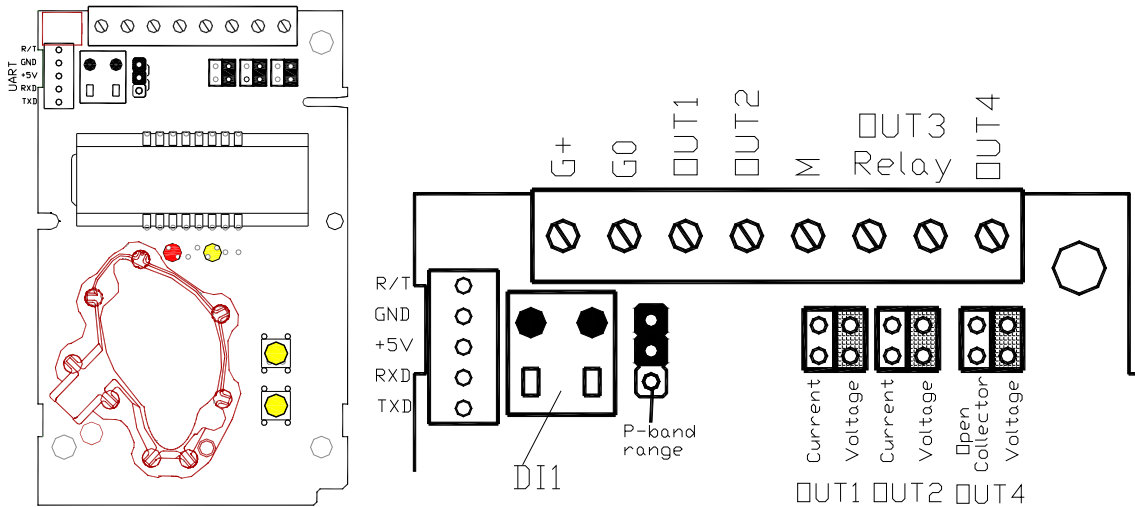

The A-SENSE-V printed circuit board. The connection terminal area with jumpers is enlarged at right. The darker positions are default settings. Terminals and jumpers are located under the top part

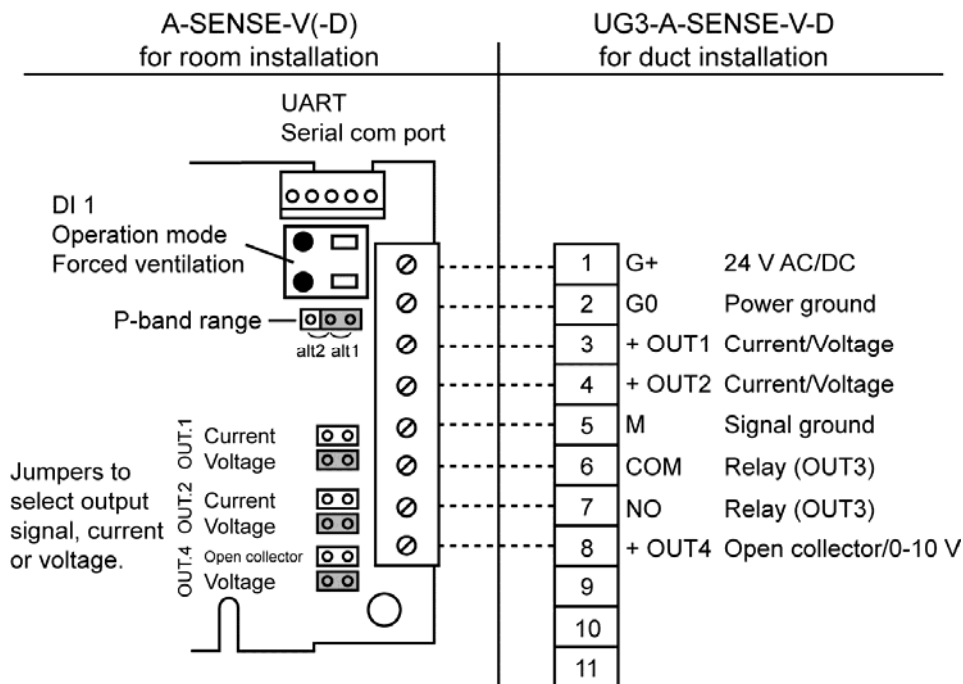

Connection of the UG3-A-SENSE-V-D via screw terminal at duct mounting

Functional description

This part describes the function of the standard configuration of A-SENSE-V. Please note that the four outputs may completely or partly have other functions. These functions may be programmed before or after the installation. To be sure that every unit is correctly programmed, in accordance to the actual application, a check by a PC and the standard UIP software (version 4.3 or higher) is necessary.

Out(1), Out(2) and Out(3) are pre-programmed *alternative* outputs for demand controlled ventilation. Out(4) is intended for connection to a heat activator, if requested.

- Out(1) = control signal of demand of coolness and air quality
(with reduced flow by extreme cold)
- Out(2) = control signal of demand of air quality
- Out(3) = ON/OFF of demand of air quality
- Out(4) = control signal of heat demand

Set point values of temperature (air cooling and heating) and air quality (CO₂) can be adjusted individually by the unit's *maintenance push buttons*. The different functions with associated outputs are seen in figures 2-7. When a set point value is changed the control curves of that parameter are parallel displaced!

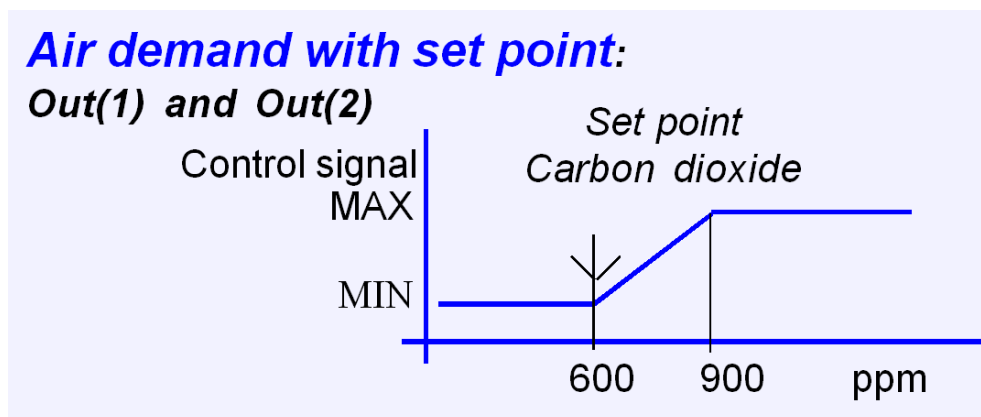
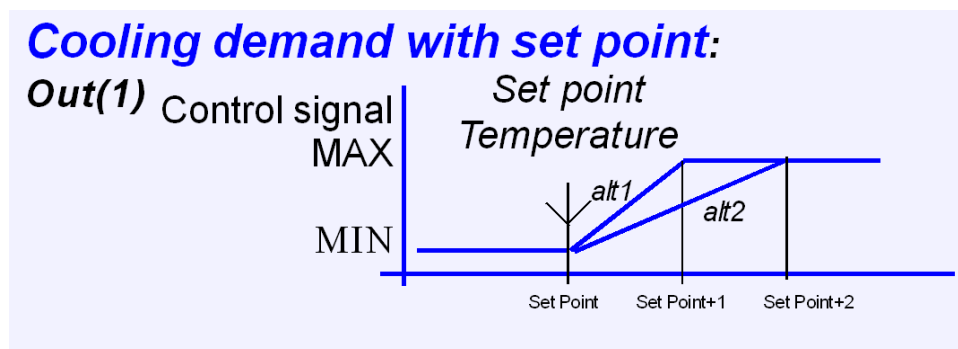

Temperature compensation of demand control:

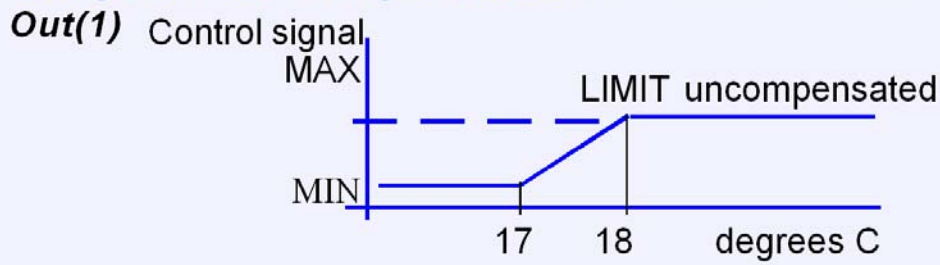

The control signal of the temperature compensation with LIMIT = set point -5 °C

Heating demand with dead zone to set point:

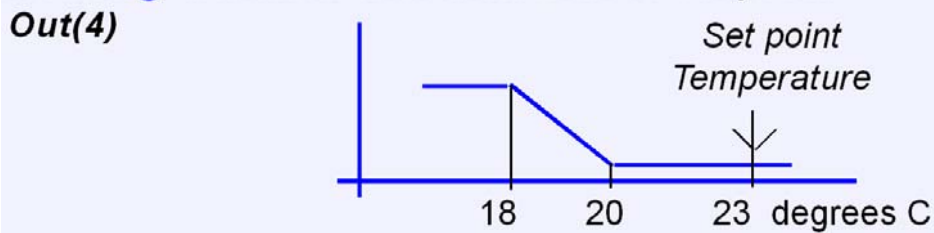

The control signal of heating demand with -3 °C dead zone to the set point

Forced ventilation With delayed effect:

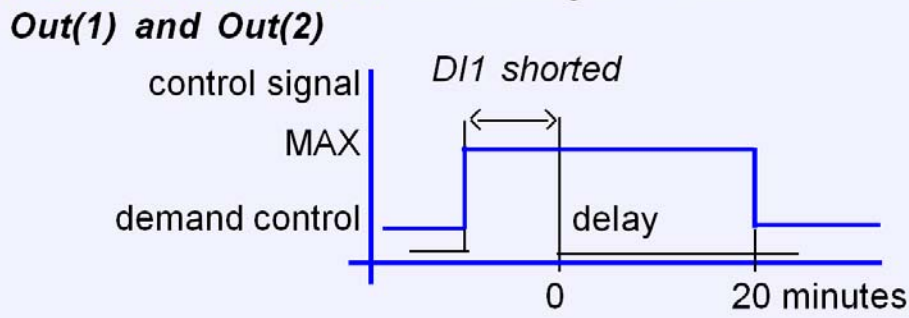

The control signal of forced ventilation with delay timer

Air demand (ON/OFF):

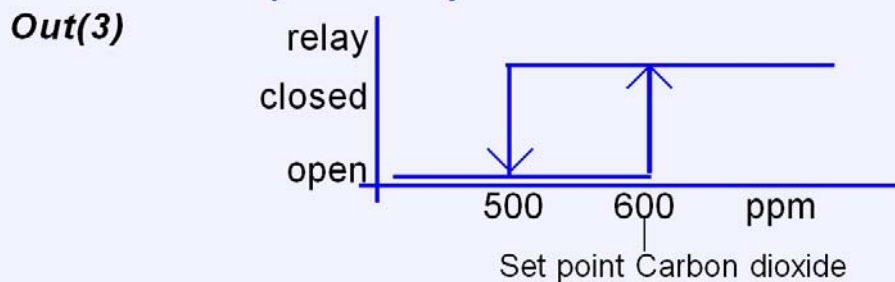

The control signal of air demand with set point

Terminal	Standard configuration	Standard settings *	Standard function
Out(1)	0-10VDC	600-900 ppm CO ₂ 23-24 °C Cut off 18-17 °C	Air control alt 1
Out(2)	0-10VDC	600-900 ppm CO ₂	Air control alt 2
Relay	Closed Open	>600 ppm CO ₂ < 500 ppm CO ₂	Air control alt 3
Out(4)	0-10 VDC	20-18 °C	Heat control

Table I. Default configuration of A-SENSE-V.
*Customer settings may be delivered at request.

Output Configurations

A label on the inner side of the sensor lid shows the configuration of the outputs at the time of product delivery. A label at the inner side of the top part shows the terminals and jumpers.

The sensors/controllers are supplied from the factory (unless otherwise ordered) with 0...10VDC linear outputs for Out(1), (2) & (4) (see Table II). If different output configurations are needed for the application, these have to be reconfigured before the unit is powered up. Each jumper selection is independent from the others. Default values are 0-10 V and 0-20 mA. Alternative measuring ranges and other start point can be selected in the PC software.

Jumper	Position	Function
Jumper for selection of P-band cool range	alt1	Jumper top position provides 1°C as P-band cool range
	alt2	Jumper bottom position provides 2°C as P-band cool range.
Out(1)	Current	Connection in position "Current" provides 0/4-20mA output range for Out(1).
	Voltage	Connection in position "Voltage" provides 0/2-10VDC output range for Out(1).
Out(2)	Current	Connection in position "Current" provides 0/4-20mA output range for Out(2).
	Voltage	Connection in position "Voltage" provides 0/2-10VDC output range for Out(2).
Out(4)	Open collector	Connection in position "Open collector" provides an open collector output. Max 0,5A, 55VDC / 40VAC (half-wave rectifier).
	Voltage	Connection in position "Voltage" provides 0-10VDC for Out(4).

Table II. Configuration jumpers for A-SENSE-V

Push Button Operation

This sensor has two push buttons, MENU and ESC, located on the front panel behind the flip-down lid. The YELLOW LED will acknowledge a successful push by a short flash. The push button MENU is available for selection of display value or maintenance commands, whereas ESC is available to escape back from a selected level.



The sensor with push buttons



The push button MENU is pushed



The push button MENU is pushed



The ENTER command is done by pushing buttons MENU and ESC at the same time for about 14 seconds

Display modes

In DISPLAY MODE the *DEFAULT* operation is that the sensor alternates between *temperature and carbon dioxide readings* presentation. The push button MENU(+) is used to select the indicated value on the display to be *the error code or the set points of temperature and CO₂*. After power up the display will always return to the Default display mode. If a *permanent change* of default values is requested the PC software is to be used.

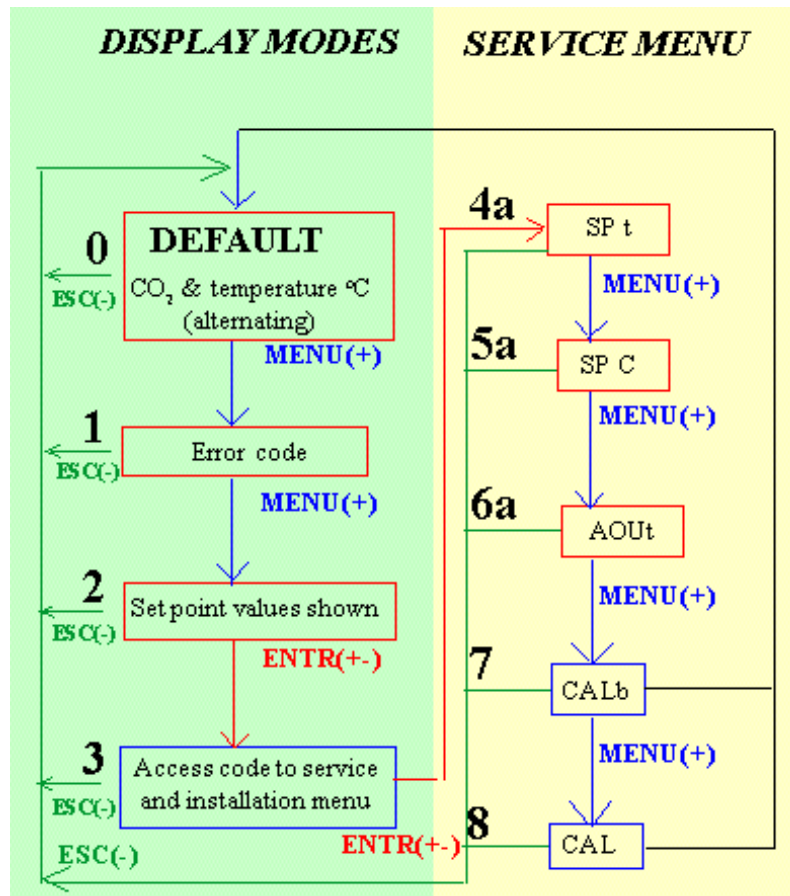

Main steps of the push button menu

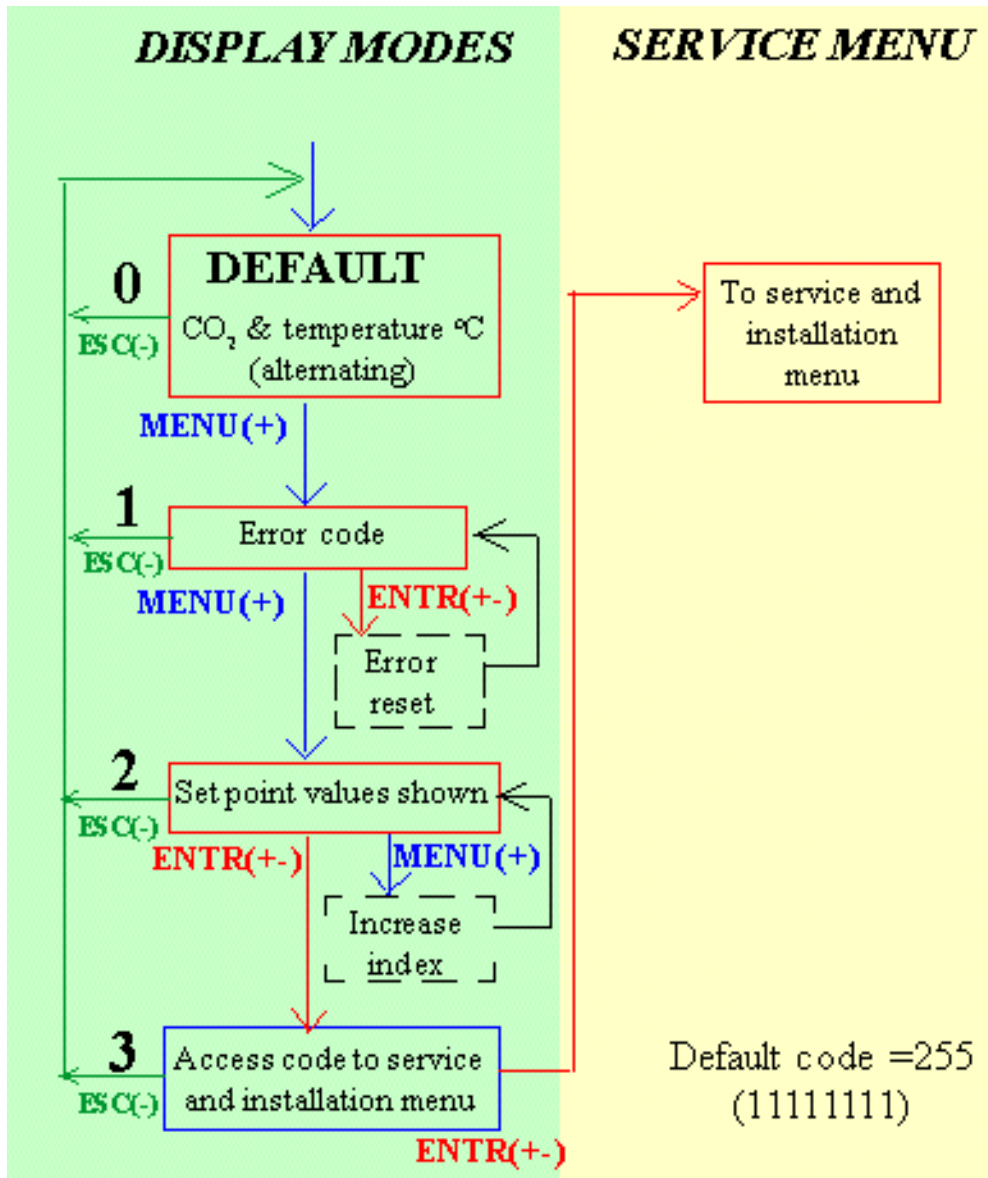

The display menu without code

Function Line	Display	Time limit	Function description
0	Temperature / CO ₂	no	DEFAULT - Normal operation
1	Exxx	yes	Error code. If no error has been detected the code E0 is shown. The error code is reset with Entr(+/-).
2	Present temperature and CO ₂ set points	no	Toggle between display of temperature and CO ₂ set point with MENU(+).
3	ECxx	yes	Access code to the service menu The default value of the code is 255 (=11111111, that is eight presses on MENU(+)). Press down MENU(+) and let it scroll until it stops. The last two digits of the code are shown. Then ENTER to accept the selected code.

This is shown on the display in the display menu

Maintenance level

A number of execution options are available from the SERVICE MENU (see Table IV). This level is accessed only from the display mode in the **set points of temperature and CO₂** selection. A two buttons push and an access code restricts access, intended for competent trained service personnel only. The Entr(+-) command is done by PUSHING MENU AND ESC AT THE SAME TIME (hold down for about 10 seconds). The access code has eight binary digits; one press at MENU(+) equals 1 and one press at ESC(-) equals 0. The code value can be changed for your personal choice from the software UIP 4.0.

Always use the ESC button to return to the DEFAULT mode. Several pushes of the ESC button may be needed to return to the DEFAULT mode. The Entr(+-) push (MENU & ESC) eventually leads to execution of functions, which causes temporary or permanently change of any parameter, that affects the system outputs!

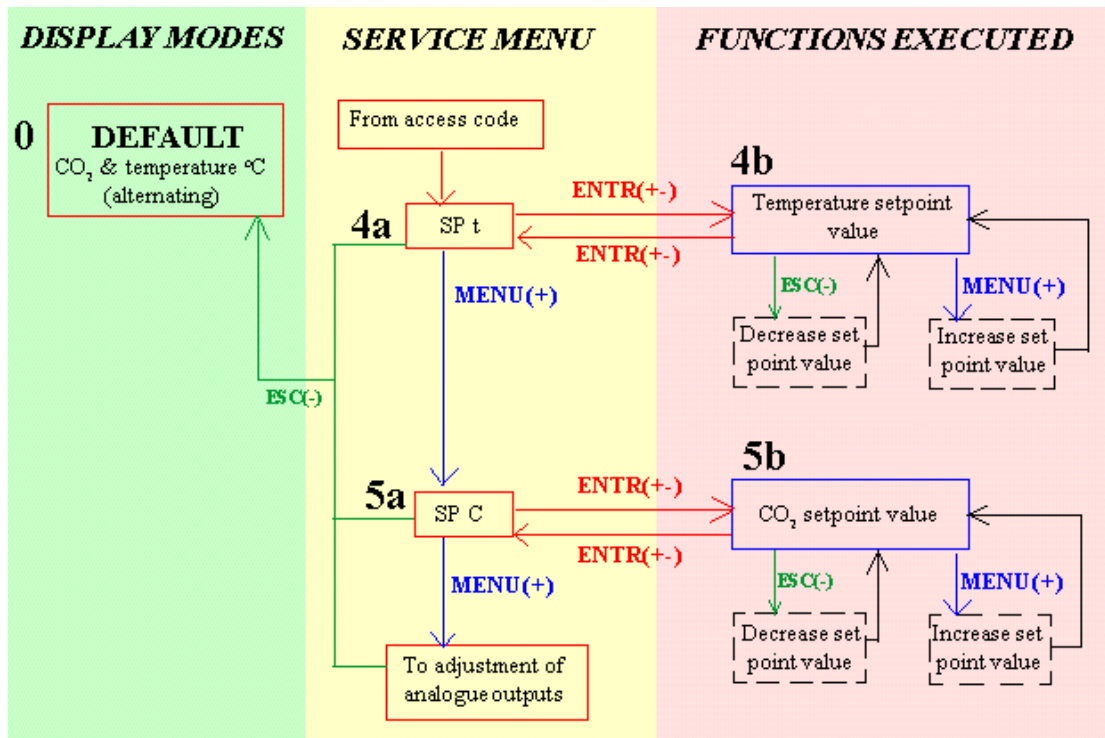

Part of the service menu for setting the setpoints

Function Line	Display	Time limit	Function description
4a	SPt	yes	For setting the temperature set point .
4b	The present temperature set point	yes	For increase / decrease of the temperature set point . The set point is increased by stepping with MENU(+) button. Decreasing is done by stepping with the ESC(-) button.
5a	SPc	yes	For setting the set point of the CO ₂ concentration
5b	The present CO ₂ set point	yes	For increase / decrease of the CO₂-concentration set point The set point is increased by stepping with MENU(+) button. Decreasing is done by stepping with the ESC(-) button.

Push button menu for setting the set points Time limit refers to an internal time-out that returns the LCD and sensor back to DEFAULT. ENTER is a simultaneous pressing on MENU and ESC.

EXAMPLE I:

Setting of temperature set point

The access code and the recalibration of the sensor are time limited. If the time limit is exceeded the sensor returns to DEFAULT.

ENTR =MENU(+) and ESC(-) are pushed simultaneously.

1. At the start of the setting the sensor is in DEFAULT.
2. Push MENU(+) once to reach the error code. The display shows E + the error code number. No error is shown as E000.
3. Push MENU(+) once. The display shows the temperature set point e.g. 20.
4. Push ENTR(+/-) once. The display shows EC and two digits. Enter the access code to the service menu. If the default code is used do like this: Push MENU(+) until the digits stop. The display shows EC55. If the correct code is not entered before the time limit exceeds the sensor returns to DEFAULT.
5. Push ENTR(+/-) once. The display shows SP t to set the temperature set point.
6. Push ENTR(+/-) once. The display shows the temperature set point e.g. 20.0C. Push MENU(+) to increase the set point value in steps of 0.2C. Push ESC(-) to decrease the set point value in steps of 0.2C.
7. Leave the unit, which returns to DEFAULT after a delay or push ENTR(+/-) once when the set point is set. The display shows SP t. Push ESC(-) to return to DEFAULT.

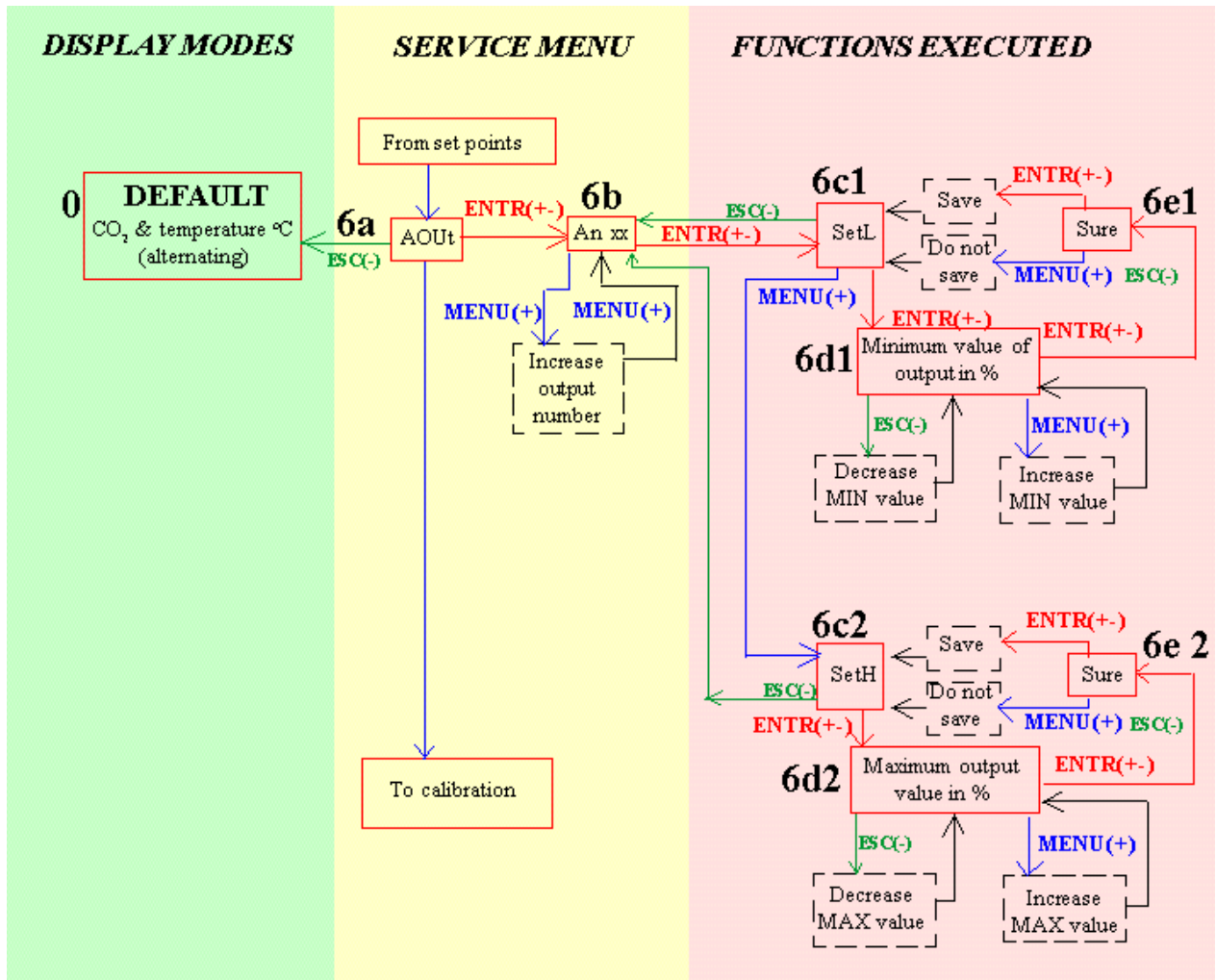

Part of the service menu for setting the MAX and MIN values.

Function Line	Display	Time limit	Function description
6a	AOUt	yes	First step of adjusting the analogue outputs MAX and MIN values
6b	An xx	no	Select analogue output by stepping with MENU(+) button
6c1	SetL	no	Leads to adjustment of the MIN value.
6d1	The present MIN value in % of FS	no	Increase the MIN value by stepping with the MENU(+) button. Decrease by stepping with the ESC(-) button. The output is set to the MIN value and can be checked with a multimeter.
6e1	Sure	no	The adjustment is saved by pressing Entr(+). Press ESC to return without saving.
6c2	SetH	no	Leads to adjustment of the MAX value
6d2	The present MAX value in % of FS	no	Increase MAX value by stepping with the MENU(+) button. Decrease by stepping with the ESC(-) button. The output is set to the MAX value and can be checked with a multimeter.
6e2	Sure	no	The adjustment is saved by pressing Entr(+). Press ESC to return without saving.

Table IV. Maintenance functions available on A-SENSE-V to set output limits. Time limit refers to an internal time-out that returns the LCD and maintenance function back to normal. ENTER is a simultaneous pressing on MENU and ESC.

PLEASE NOTE! If a power failure happens when the sensor has OUT1...4 locked to min/max limits, then the sensor will have this output locked when the power returns. It is necessary to enter this menu item and release the output manually!

EXAMPLE II:

Setting of the MAX value of the analogue outputs

The access code is time limited. If the time limit is exceeded the sensor returns to DEFAULT.

ENTR =MENU(+) and ESC(-) are pushed simultaneously.

1. At the start of the setting the sensor is in DEFAULT.
2. Push MENU(+) once to reach the error code. The display shows E + the error code number. No error is shown as E000.
3. Push MENU(+) once. The display shows the temperature set point e.g. 20.
4. Push ENTR(+/-) once. The display shows EC and two digits. Enter the access code to the service menu. If the default code is used do like this: Push MENU(+) until the digits stop. The display shows EC55. If the correct code is not entered before the time limit exceeds the sensor returns to DEFAULT.
5. Push ENTR(+/-) once. The display shows SP t to set the temperature set point.
6. Push MENU(+) once to reach the carbon dioxide set point. The display shows SP C.
7. Push MENU(+) once to reach the setting of analogue outputs. The display shows AOUt.
8. Push ENTR(+/-) to reach the output to be set. The display shows An and two digits e.g. An 01. Step to the requested output by pushing MENU(+).
9. Push ENTR(+/-) to reach the setting of the MIN value. The display shows Set L.
10. Push MENU(+) to reach the setting of the MAX value. The display shows Set H.
11. Push ENTR(+/-) to set the MAX value of the output. The display shows the numerical value in % e.g. the standard setting 100.0 % or previously set value. Push MENU(+) to increase the MAX value. Push ESC(-) to decrease the MAX value. Push ENTR(+/-). The display shows Sure. Push ENTR(+/-) to save the setting and return to Set H. Push MENU(+) or ESC(-) to return to Set H without saving the new setting. Push ESC(-) to return to the output to be set,

item 12. Push ESC(-) once again to return to the setting of analogue outputs
 item 11. Push ESC(-) three times to return to DEFAULT.

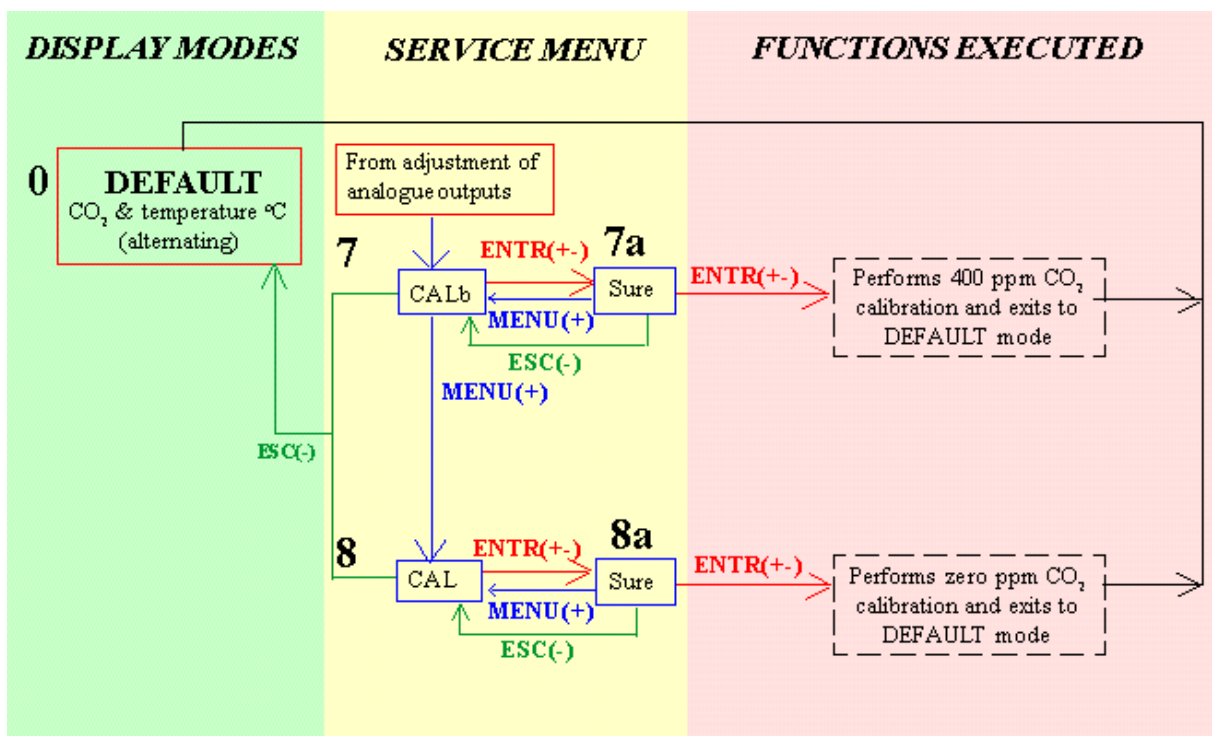

Part of the service menu with calibration functions

Function Line	Display	Time limit	Function description
7	CALb	yes	Background calibration = CO₂-sensor calibration with fresh air. An easy way to correct the zero point error. The sensor needs fresh air (380-420 ppm CO ₂). The calibration must be confirmed by pressing Entr(+).
7a	Sure	yes	Confirm that a background calibration shall be done.
8	CAL	yes	Zero point calibration of the CO ₂ sensor. The sensor needs zero gas. See the zero point calibration instruction. The calibration must be confirmed by pressing Entr(+).
8a	Sure	yes	Confirm that a zero point calibration shall be done.

Table IV. Calibration functions available on A-SENSE-V. Time limit refers to an internal time-out that returns the LCD and maintenance function back to normal. ENTER is a simultaneous pressing on MENU and ESC.

EXAMPLE III:

Setting of set points for temperature and carbon dioxide concentration, the MAX and MIN values of the analogue outputs and calibration of the sensor

DISPLAY = the sensor alternates between temperature and carbon dioxide measurements.

The access code and the recalibration of the sensor are time limited. If the time limit is exceeded the sensor returns to DEFAULT.

ENTR =MENU(+) and ESC(-) are pushed simultaneously.

1. At the start of the setting the sensor is in DEFAULT.
2. Push MENU(+) once to reach the error code. The display shows E + the error code number. No error is shown as E000.
(Push ESC(-) to return to DEFAULT if requested)
3. Push MENU(+) once. The display shows the temperature set point e.g. 20.0 C and the carbon dioxide set point e.g. 750ppm.
(Push ESC(-) to return to DEFAULT if requested.)
4. Push ENTR(+/-) once. The display shows EC and two digits. Enter the access code to the service menu. If the default code is used do like this: Push MENU(+) until the digits stop. The display shows EC55. If the correct code is not entered before the time limit exceeds the sensor returns to DEFAULT.
5. Push ENTR(+/-) once. The display shows SP t to set the temperature set point.
6. Push ENTR(+/-) once. The display shows the temperature set point e.g. 20.0C.
Push MENU(+) to increase the set point value in steps of 0.2C. Push ESC(-) to decrease the set point value in steps of 0.2C.
7. Push ENTR(+/-) once when the set point is set. The display shows SP t.
Push ESC(-) to return to DEFAULT.
8. Push MENU(+) once to reach the carbon dioxide set point.
The display shows SP C.
9. Push ENTR(+/-) once. The display shows the carbon dioxide set point e.g. 750 ppm. Push MENU(+) to increase the set point value in steps of 50 ppm. Push ESC(-) to decrease the set point value in steps of 50 ppm.
10. Push ENTR(+/-) once when the set point is set. The display shows SP C.

Push ESC(-) to return to DEFAULT.

11. Push MENU(+) once to reach the setting of analogue outputs. The display shows AOuT.
12. Push ENTR(+/-) to reach the output to be set. The display shows An and two digits e.g. An 01. Step to the requested output by pushing MENU(+).
13. Push ENTR(+/-) to reach the setting of the MIN value. The display shows Set L.
14. Push ENTR(+/-) to set the MIN value of the output. The display shows the numerical value in % e.g. the standard setting 0.0 % or previously set value. Push MENU(+) to increase the MIN value. Push ESC(-) to decrease the MIN value. Push ENTR(+/-). The display shows Sure. Push ENTR(+/-) to save the setting and return to Set L. Push MENU(+) or ESC(-) to return to Set L without saving the new setting.
15. Push MENU(+) to reach the setting of the MAX value. The display shows Set H.
16. Push ENTR(+/-) to set the MAX value of the output. The display shows the numerical value in % e.g. the standard setting 100.0 % or previously set value. Push MENU(+) to increase the MAX value. Push ESC(-) to decrease the MAX value. Push ENTR(+/-). The display shows Sure. Push ENTR(+/-) to save the setting and return to Set H. Push MENU(+) or ESC(-) to return to Set H without saving the new setting. Push ESC(-) to return to the output to be set, item 12. Push ESC(-) once again to return to the setting of analogue outputs item 11.
17. Push MENU(+) to reach the calibration with fresh air. The sensor needs fresh air, air with 400 ppm carbon dioxide. The display shows CALb. Push ENTR(+/-). The display shows Sure. Push ENTR(+/-) to confirm that a background calibration should be done. After completed background calibration the sensor returns to DEFAULT. If a background calibration should not be executed push MENU(+) or ESC(-). The background calibration has a time limit.
18. Push MENU(+) to reach the zero point calibration. The sensor needs carbon dioxide free air or gas. . The display shows CAL. Push ENTR(+/-). The display shows Sure. Push ENTR(+/-) to confirm that a zero point calibration should be done. After completed zero point calibration the sensor returns to DEFAULT. If a zero point calibration should not be executed push MENU(+) or ESC(-). The zero point calibration has a time limit.

Functional test

The unit has two LED's - yellow and red - on the front panel (found under the front lid). These LED's indicate the status of the controller.



The A-SENSE-V-D with LEDs, push buttons and display

Yellow LED - "Call for maintenance" is lit, if an error flag is set or the measurement is out of range. This information is also shown on the display by the wrench icon. Any push button press, or executed maintenance function, is acknowledged by emission from this LED.

Red LED - "Relay active" is lit, when the relay is activated (contact closed).

A simple and visual functional test can easily be performed. Take a breath and blow the air from a distance of a few centimetres on the sensor. The sensor will detect a rapid increase in the carbon dioxide concentration. The red LED is lit when the CO₂ concentration goes above the pre-set value. If the sensor is connected to a controller, the flow of the ventilation system will eventually increase by change of the fan speed or opening of a damper actuator (depending on the installation/application).

Test gas verification

If the measurement of a sensor is to be verified, a test gas with carefully determined concentration of CO₂ must be used. For zero calibration pure nitrogen or air that has passed through a chemical absorber should be used. Insert a 4 mm plastic tubing in the test gas inlet at the bottom of the wall plate. The plastic tubing should be inserted as far as possible into the inlet. Flow test gas at a rate of about 0,5 litre/minute should be used. The Service bag *F0005* can be used to produce carbon dioxide free air. Check the CO₂ value of the display or the voltage of the output with a multimeter when the value has stabilized.

PLEASE NOTE!

The sensor accuracy is defined at continuous operation (at least 3 weeks after installation)

Self-diagnostics

The system contains complete self-diagnostic procedures. A full system test is executed automatically every time the power is turned on. For *A-SENSE-V* the internal voltage regulators and outputs are checked. In addition, constantly during operation, the sensor probes are checked against failure by checking the valid dynamic measurement ranges. These different system checks return error bytes to the system RAM. If any error is detected, the yellow LED will be lit until the error has vanished and the error flag is reset. "Warm up" and "Out of Range" are the only bits that are reset automatically after return to normal state. All other error bits have to be reset manually after return to normal state – either by pushing MENU & ESC buttons simultaneously for (=Entr(+)) or by power off and restart.

By pushing the push button "MENU" the error code *number Exxx* is shown on the LCD. Descriptions of the different codes are listed below.

Error code and action plan

Bit #	Error code	Error description	Suggested action
0	N/A	Fatal Error Yellow LED continuously flashes. Push buttons are not operating.	Try to restart sensor by power OFF/ON. Contact local distributor
1	2	Reserved	
2	4	Algorithm Error. Indicate wrong EEPROM configuration.	Try to restart sensor by power OFF/ON. Check detailed settings and configuration with UIP software version 4.3 and higher. Contact local distributor
3	8	Output Error Detected errors during output signals calculation and generation.	Check connections and loads of outputs. Check detailed status of outputs with UIP software version 4.3 and higher.
4	16	Self-Diagnostic Error. May indicate the need of zero calibration or sensor replacement.	Check detailed self-diagnostic status with UIP software version 4.3 and higher. Contact local distributor
5	32	Out Of Range Error Accompanies most of other errors. Can also indicate overload or failures of sensors and inputs. Resets automatically after source of error disappearance.	Try sensor in fresh air. Check connections of temperature and relative humidity probe. Check detailed status of measurements with UIP software version 4.3 and higher. <i>See Note 1!</i>
6	64	Memory Error Non-fatal error during memory operations.	Check detailed settings and configuration with UIP software version 4.3 and higher.
7	128	Warm Up state Is always set after power up or power failure. Resets after restart sequence	If it doesn't disappear in half a minute, check power stability.

Note 1. Any probe is out of range. Occurs, for instance, during over exposure of CO₂ sensor, in which case the error code will automatically reset when the measurement values return to normal. Could also indicate the need of zero point calibration. A background calibration using push button function "bCAL" will cure this error (a more exact zero calibration using "CAL" may be performed later, if required). If the CO₂ readings are normal, and still the error code remains, the temperature or relative humidity sensor can be defect or the connections to these are broken.

Remark: If several errors are detected at the same time the different error code numbers will be added together into one single error code!

Maintenance

The A-SENSE-V is basically maintenance free. An internal self adjusting calibration function takes care of normal long term drift associated to the CO₂ sensor. To secure the highest accuracy, a time interval of five years is recommended between CO₂ calibrations, unless some special situations have occurred. A zero calibration can be performed by use of the push button functions, or for a complete overview by use of a PC together with the *UIP software version 4.3* (or higher). This software can be obtained from Calectro free of charge. The RS232-cable, article code *A232 CABLE*, is needed and can be ordered from Calectro. The cable is to be connected to the UART port slide connector. For change of control parameters and re-calibration (CO₂ and temperature) this PC tool has to be used. The check can be done on site without interfering with the ventilation system.

This product is in accordance with the EMC 2004/108/EC, 92/31/EEG including amendments by the CE-marking Directive 93/68/EEC

The product fulfils the following demands: EN 61000-4-2 level 2, EN 61000-4-3 level 2, EN 61000-4-4 level 4, EN 61000-4-6, EN 61000-4-8 level 4, EN 55022 class B



Distributor

Calectro AB

Box 4113

SE-426 04 VÄSTRA FRÖLUNDA, SWEDEN

Telephone: +46-(0)31-69 53 00

Telefax: +46-(0)31-29 32 91

Home page: www.calectro.com

E-mail: info@calectro.com