

A-SENSE-VAV and UG3-A-SENSE-VAV

Carbon dioxide and temperature controller



TECHNICAL DATA

Power supply:	24V AC/DC $\pm 20\%$, 50-60 Hz
Current drain:	< 3 W (120 mA) average
Linear outputs:	OUT1 and OUT2: 0-10 V DC, max 2 mA or 0-20 mA, $R_{load} < 500 \text{ Ohm}$. Outputs are configured with jumpers for voltage/current. OUT4: 0-10V DC or open collector, configured with jumper. Max 0.5 A, 60V DC/40V AC
Relay output:	OUT3: NO. Contactless relay, min. load 1 mA/5 V, max. load 0.5 A/125V AC or 1A/24V DC
Operating temperature:	0 to +50°C
Storage temperature:	-20 to +70 °C
Operating humidity:	0 to 95% RH (non-condensing)
Start time:	1 min. (@ full spec ≤ 15 minutes)
Sensor life expectancy:	>15 years
Measurement principle:	Non-dispersive infrared (NDIR) with automatic baseline correction (ABC)
Gas collection:	Diffusion
Response time (T1/e):	2 min. diffusion time
Accuracy:	Normally $\pm 1\%$ of measuring range $\pm 5\%$ of measured value
Annual zero point drift:	< $\pm 0.3\%$ of measuring range
Temperature measurement principle:	Thermistor
Measuring range:	-20 to +60 °C
Accuracy:	$\pm 0,5^\circ\text{C}$
Dimensions (HxWxD):	Wall installation 120x82x30 mm Duct installation 150x180x154 mm
PC software:	UIP4
Protection:	Wall installation IP20 Duct installation IP54

FEATURES

- Cost-optimised for direct control of damper or speed-controlled fans
- Alternative/additional control outputs
- Gives reduced energy costs with demand-controlled ventilation
- Automatic self-diagnostics
- Normally maintenance-free
- Enclosure options, wall and duct
- Network communication via RS485 as an option
- Modbus as an option

FUNCTION

OUT1, OUT2 and OUT3 are pre-programmed outputs for demand-controlled ventilation. OUT4 is intended for connection to a linear heat activator, if requested.

- OUT1 = control signal according to demand for cooling and air quality (with flow reduction in extreme cold)
- OUT2 = control signal according to demand for air quality only
- OUT3 = ON/OFF according to demand for air quality only
- OUT4 = control signal according to heating demand

Set points for temperature (air cooling and additional heat) and air quality (CO_2) can be adapted individually via the unit's maintenance pushbuttons.

When a set point is changed, all control curves for this parameter are shifted parallel.

The standard configuration for A-SENSE-VAV, with associated settings, is typical for many VAV applications. Other control parameters and strategies can also be programmed from a PC with suitable software. For this purpose, eight freely programmable linear functions (P-band) and two timer functions controlled from the DI1 terminal are available.

Up to four of the twelve available functions can be addressed to each of the four outputs in such a way that the total, or alternatively the highest value, is transformed into an output signal. In addition, for OUT1 and OUT2, the outputs can be limited within defined MIN and MAX values. These MIN and MAX values can be set/updated from the pushbutton menu in service. The values of the outputs are updated every four seconds. This interval and other functions and settings can be changed with the UIP4 software.

USE

A-SENSE-VAV is intended to control the ventilation in rooms where people are present. The sensor is a basic component which is suitable for many different ventilation strategies.

INSTALLATION

Wall mounted version: Mounting place; avoid exposure of direct sunlight, air draught from ventilation, doors or windows. When mounted over a conduit box or conduits, these must be made tight in order to avoid air draught that could affect the sensors function and accuracy.

A-SENSE-VAV and UG3-A-SENSE-VAV

Carbon dioxide and temperature controller



INSTALLATION CONT.

Duct mounted version: The venturi pipe is made of aluminium and can easily be shortened to suit the diameter of the duct. Hole diameter is 38 mm. For insulated and/or circular ducts use a special mounting bracket and a gasket. The hole diameter is then 51 mm.

The length of the venturi pipe shall be chosen based upon how wide the ventilation duct is. The venturi pipes are available in 3 lengths; 0,6, 1,5 and 2,8 m. When the ventilation duct is wider than 0,6 m (dia), the venturi pipe should penetrate the **whole** duct. Please see below sketch.

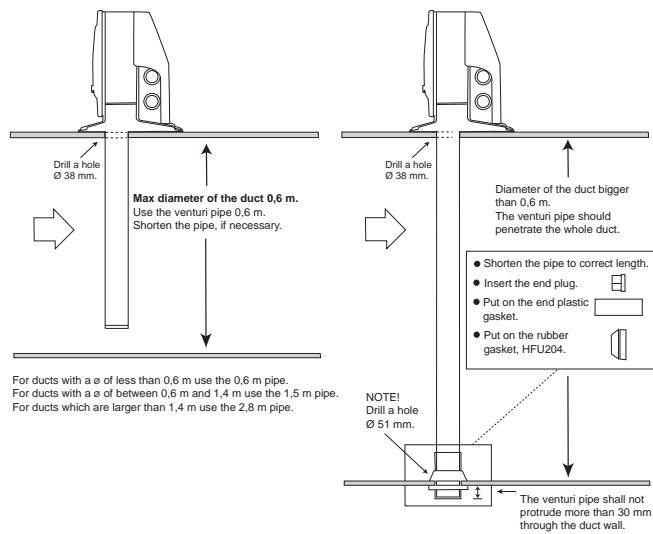

For more information please see the installation instruction enclosed with the product.

MAINTENANCE

In room installations, A-SENSE is normally maintenance-free if the auto-calibration function (ABC) is activated.

ORDERING EXAMPLE

Item code	Designation
A-SENSE-V	Without display window
A-SENSE-V-D	With display window
A-SENSE-V-IP54	IP54, without display window
A-SENSE-V-IP54-D	IP54, with display window
UG3-A-SENSE-V-D	Duct sensor with display window

ACCESSORIES

Item code	Designation
USB CABLE	Programming cable
2001M	Zero-calibration bag
VR-0.6M	Venturi pipe 0.6 meter for UG-3
VR-1.5M	Venturi pipe 1.5 meter for UG-3
VR-2.8M	Venturi pipe 2.8 meter for UG-3
ST-EXTEND	Extension of venturi tube VR & ST, 1.06M
UG-MB	Mounting bracket for UG-3/4

WIRING DIAGRAM

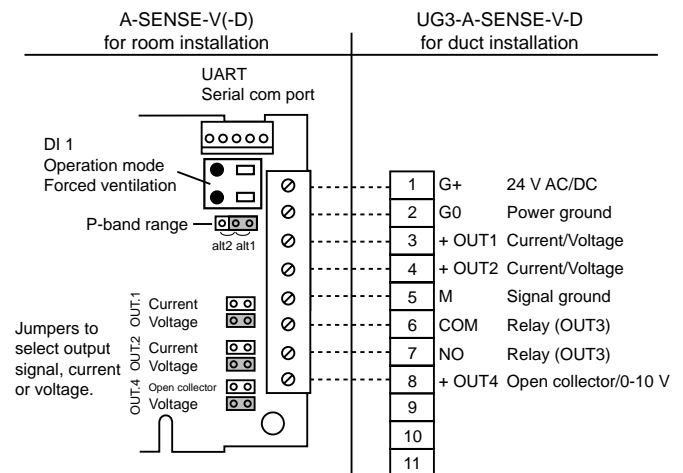

DIMENSIONS (mm)

