

IOMB-04, I/O-MODULE WITH MODBUS COMMUNICATION

2 digital and 8 configurable inputs and 2 digital and 2 analogue outputs.

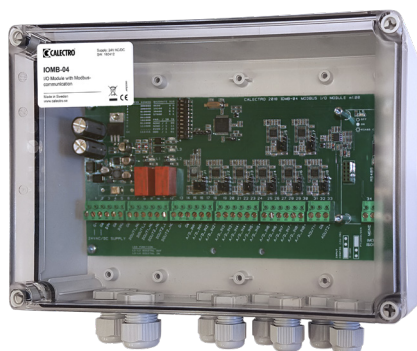

TECHNICAL DATA

Supply voltage:	24V AC/DC $\pm 10\%$
Power consumption	<100 mA
Analogue inputs:	8 x 0-10V DC, (input impedance 5.3 k Ω) or 8 x Pt1000/Ni1000LG or potential-free closing contact
Analogue outputs:	2 x 0-10V DC
- Max load/output:	>5 k Ω imp.
Digital inputs:	2, via potential-free closing contact
Digital output, relay:	2 x 5A, 250V
Indicators LED:	4 amber: Digital I/O, 1 green: Operation/ communication
Communication:	Modbus RTU (RS485)
- RS485 unit load:	96kOhm (1/8 UL)
- Parity selectable:	None, even, odd
- Stop bits:	1 or 2, selectable for no parity
- Speed (baud rate, kbps):	9.6 / 19.2 / 38.4 / 57.6
- Address:	1-64
- Terminating resistor:	120 Ω via jumper J9
Ambient temperature:	-20 till +50°C
Cable inlets:	6 x M16 and 2 x M20
Weight grams:	778 g
Dimensions (WxHxD):	250x175x75 mm
Protection class:	IP67

ORDERING EXAMPLE

Item code	Description
IOMB-02	I/O Module with Modbus communication, 8 in & 4 out / PWM-output, transparent cover
IOMB-03	I/O Module with Modbus communication, 6 in & 6 out, transparent cover
IOMB-04	I/O Module with Modbus communication, 10 in & 4 out, transparent cover
IOMB-TCP/IP	Modbus-IP gateway for IOMB

CHARACTERISTICS

- Gathers sensor signals
- Communicates with Modbus RTU
- Universal
- Microprocessor technology
- Operation indicator
- Adjustable setting for communication interference
- Compatible with both Pt1000 and Ni1000LG

FUNCTION

IOMB-04 is an IP67 enclosed I/O module that transmits measurement and control signals via Modbus to and from DUC regulators. IOMB-04 has 2 digital and 8 configurable inputs and 2 digital and 2 analogue outputs.

The analogue inputs can be configured (via jumpers) to receive either 0-10V, temperature sensor (Pt1000/Ni1000LG) or potential-free closing contact. Choice of Pt1000 or Ni1000LG is set in Modbus register 4x0044-4x0051. The analogue outputs have 0-10V output.

The digital in and outputs both have an amber LED. The green operation LED blinks during Modbus communication.

Addressing, choice of parity and baud rate is set with DIP switches. IOMB-04 should be de-energised at these settings

The housing has 6 M16 and 2 M20 cable fittings.

Selectable default function: IOMB-04 has a selectable function for dealing with interruptions in the Modbus communication. This means that the digital and analogue outputs can be set individually if the Modbus communication is interrupted for a certain amount of time. The time for communication interruption before the default function kicks in can be set between 1 and 600 seconds. If set to 0 seconds then the function is deactivated (factory setting).

As an accessory, a Modbus-IP gateway is available for retrofit.

APPLICATION

IOMB-04 is used to collect and distribute analogue and digital signals to and from regulators (DUC) using Modbus RTU communication.

MOUNTING

IOMB-04 is wall-mounted indoors. For more information please refer to the installation instructions supplied with the product.

MAINTENANCE

IOMB-04 is maintenance-free.

IOMB-04, I/O-MODULE WITH MODBUS COMMUNICATION

2 digital and 8 configurable inputs and 2 digital and 2 analogue outputs.



WIRING DIAGRAM

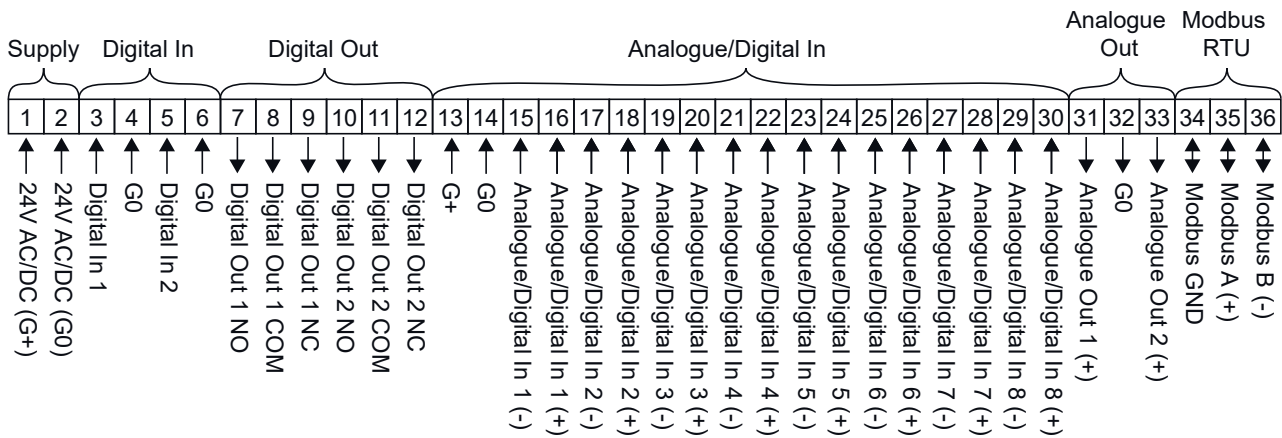

EXAMPLE CONNECTIONS

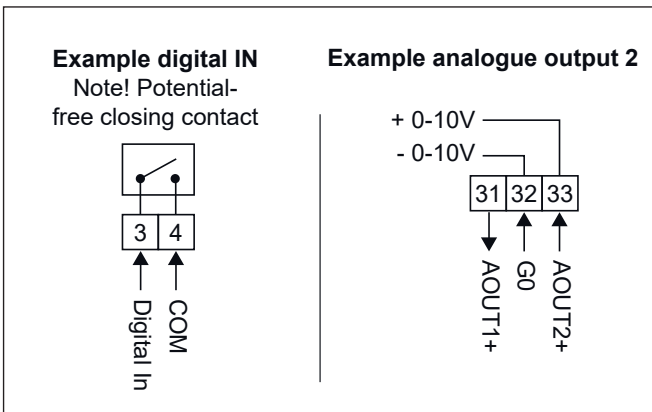
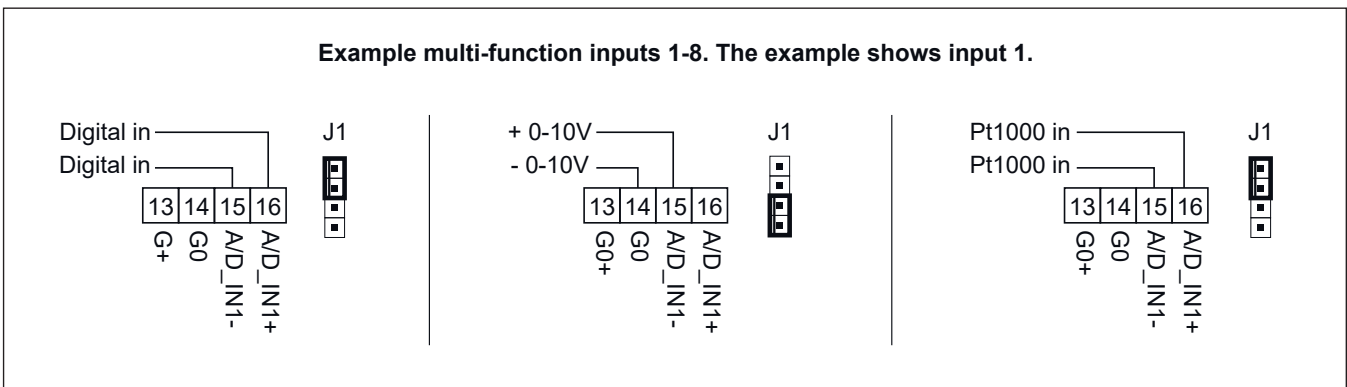

MULTI-FUNCTION INPUTS, CONFIGURATION OF JUMPERS

J1: A/D_IN1 (Ditto for jumpers J2-J8)

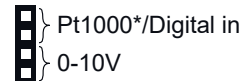

* Choice of Pt1000 or Ni1000LG is set in Modbusregister 4x0044-51.

LED INDICATION

LED Diod	Function	Status
L1	DOUT1	Active
L2	DOUT2	Active
L3	DIN1	Closed
L4	DIN2	Closed
L5	Operation	
L5 Blinks	Modbus Communication	Active

MODBUS-COMMUNICATION

Reference	Description
0x	Read/Write Discrete Outputs or Coils
1x	Read Discrete Inputs
3x	Read Input Registers
4x	Read/Write Output or Holding registers

MODBUS SETTINGS

For Modbus register and Modbus addresses, please refer to the installation instructions supplied with the product.