

CRH-RW-24V INSTALLATION INSTRUCTIONS

EN



ENGLISH

Humidity and temperature sensor for room installation.

TECHNICAL DATA

Supply voltage: 24V AC/DC $\pm 10\%$

Power consumption: 3 mA

Analog outputs
(minimum input impedance of 10 k Ω)

0-10V DC: Atmospheric humidity

0-100% RH

0-10V DC: Temperature 0-50°C

RH accuracy:

0-80% RH: Normal $\pm 2\%$

80-100% RH: Normal $\pm 3\%$

Temperature

accuracy: Normal $\pm 0.3^\circ\text{C}$

Ambient temperature: 0-50°C

Housing material: ABS

Weight: 62 g

Protection class: IP20

FUNCTION

CRH has a factory calibrated CMOS humidity and temperature sensor element with I2C communication and low power consumption. It has high accuracy and excellent long-term stability. CRH has extremely low power consumption providing very low self-heating, a prerequisite for high measurement accuracy of relative humidity.

USE

CRH is used for controlling the humidity and temperature of indoor environments.

INSTALLATION

CRH is wall-mounted indoors and is large enough to cover an electrical box.

Opening the cover

The cover has a snap on/off function and is easy to remove using a screwdriver. Se fig. 3.

Placement

Install CRH away from direct sunlight and draft from ventilation, doors and windows. When mounted on an electrical box or conduit it should be sealed to avoid draft that could affect its accuracy.

Fit the CRH with the grids top and bottom to permit the flow of air.

Place the sensor a minimum of 10mm from a doorframe or a wall to allow easy access to the cover. Se fig. 4.

CRH has a cable inlet at the rear for connecting to an electrical box or conduit

and spacers that give a 1mm gap between the wall and the box through which to thread surface connection wires. Wires that are thicker than 1mm can be threaded through the grid. Part of the grid can be removed if a larger hole is required.

Removing the circuit board

Loosen the sensor's circuit board by gently raising the locking clip. Se fig. 5.

MAINTENANCE

CRH requires no maintenance.

FIGURES

FIG. 1

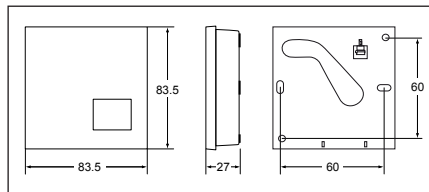

FIG. 2

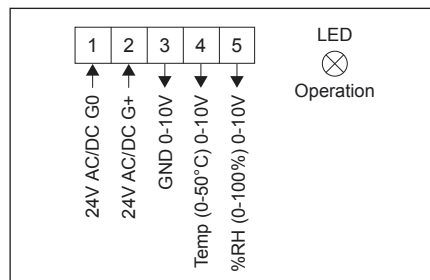

FIG. 3

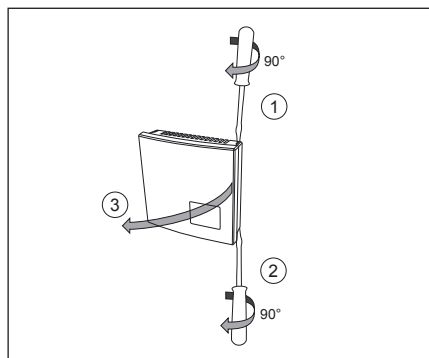

FIG. 4

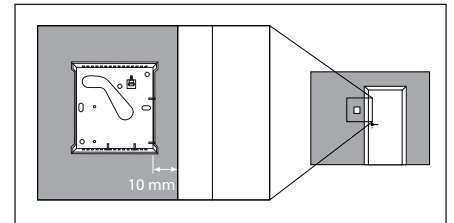

FIG. 5

